

TELOS Hx1/Hx2

Digital Hybrid Telephone Interface



USER'S MANUAL

Manual Version 1.4.2 for software version 1.4 or later
December, 2018

Telos[®]

THE TELOS ALLIANCE[®]

TelosAlliance.com

User Warnings and Cautions

The installation and service instructions in this manual are for use by qualified personnel only. To avoid electric shock, do not perform any servicing other than that contained in the operating instructions unless you are qualified to do so. Refer all servicing to qualified personnel

This instrument has an autoranging line voltage input. Ensure the power voltage is within the specified range of 100-240VAC. The ~ symbol, if used, indicates an alternating current supply.



This symbol, wherever it appears, alerts you to the presence of uninsulated, dangerous voltage inside the enclosure – voltage which may be sufficient to constitute a risk of shock.



This symbol, wherever it appears, alerts you to important operating and maintenance instructions. Read the manual.

CAUTION: HAZARDOUS VOLTAGES

The instrument power supply incorporates an internal fuse. Hazardous voltages may still be present on some of the primary parts even when the fuse has blown. If fuse replacement is required, replace fuse only with same type and value for continued protection against fire.

WARNING:

The product's power cord is the primary disconnect device. The socket outlet should be located near the device and easily accessible. The unit should not be located such that access to the power cord is impaired. If the unit is incorporated into an equipment rack, an easily accessible safety disconnect device should be included in the rack design.

To reduce the risk of electrical shock, do not expose this product to rain or moisture. This unit is for indoor use only.

This equipment requires the free flow of air for adequate cooling. Do not block the ventilation openings on the rear and sides of the unit. Failure to allow proper ventilation could damage the unit or create a fire hazard. Do not place the units on a carpet, bedding, or other materials that could interfere with any panel ventilation openings.

If the equipment is used in a manner not specified by the manufacturer, the protection provided by the equipment may be impaired.

USA CLASS A COMPUTING DEVICE INFORMATION TO USER.

WARNING:

This equipment generates, uses, and can radiate radio-frequency energy. If it is not installed and used as directed by this manual, it may cause interference to radio communication. This equipment complies with the limits for a Class A computing device, as specified by FCC rules, part 15, subpart j, which are designed to provide reasonable protection against such interference when this type of equipment is operated in a commercial environment. Operation of this equipment in a residential area is likely to cause interference. If it does, the user will be required to eliminate the interference at the user's expense.

Note: objectionable interference to TV or radio reception can occur if other devices are connected to this device without the use of shielded interconnect cables. FCC rules require the use of shielded cables.

CANADA WARNING:

“This digital apparatus does not exceed the Class A limits for radio noise emissions set out in the radio interference regulations of the Canadian department of communications.”

“Le présent appareil numérique n’émet pas de bruits radioélectriques dépassant les limites applicables aux appareils numériques (de Class A) prescrites dans le règlement sur le brouillage radioélectrique édicté par le ministère des communications du Canada.”

CE CONFORMANCE INFORMATION:

This device complies with the requirements of the EEC council directives:

- ◆ 93/68/EEC (CE MARKING)
- ◆ 73/23/EEC (SAFETY – LOW VOLTAGE DIRECTIVE)
- ◆ 89/336/EEC (ELECTROMAGNETIC COMPATIBILITY)

Conformity is declared to those standards: EN50081-1, EN50082-1.

Trademarks, Patents, and Licenses

Telos is a trademark of TLS Corp. All other trademarks are the property of their respective holders.

All versions, claims of compatibility, trademarks, etc. of hardware and software products not made by The Telos Alliance which are mentioned in this manual or accompanying material are informational only. The Telos Alliance makes no endorsement of any particular product for any purpose, nor claims any responsibility for operation or accuracy. We reserve the right to make improvements or changes in the products described in this manual which may affect the product specifications, or to revise the manual without notice.

This document and its content are copyrighted by TLS Corporation and may not be copied, reproduced, or distributed in any form without expressed written permission.

Patent information can be found at www.TelosAlliance.com/legal

Updates

Telos Hx1 and Hx2 features and operations are determined largely by software. The Telos Alliance strives to provide the most stable and feature-rich software available. We encourage you to check for software updates from time to time by visiting our website or by contacting us directly.

Feedback

We welcome feedback on any aspect of our products or this manual. In the past, many good ideas from users have made their way into software revisions or new products. Please contact us with your comments or suggestions.

We support you...

By Phone/Fax

You may reach our Telos Support Team in emergencies by calling +1 216-622-0247. For billing questions or other non-emergency technical questions, call +1 216-241-7225 between 9:00 AM to 5:00 PM USA Eastern Time, Monday through Friday.

By Email.

Non-emergency technical support is available at Support@TelosAlliance.com.

By Web

The Telos Web site has a variety of information that may be useful for product selection and support. The URL is <https://www.telosalliance.com/Telos>.

SERVICE

You must contact Telos Alliance before returning any equipment for factory service. We will need your unit's serial number, located on the back of the unit. We will issue a return authorization number, which must be written on the exterior of your shipping container. Please do not include cables or accessories unless specifically requested by the Technical Support Engineer. Be sure to adequately insure your shipment for its replacement value. Packages without proper authorization may be refused. US customers, please contact Telos Alliance Technical Support at +1-216-622-0247. All other customers should contact local representative to make arrangements for service.

Warranty



For the latest Telos Alliance warranty, visit: telosalliance.com/warranty

Register your product

Register your product today to get the full benefits of our warranty, support, and product updates. telosalliance.com/product-registration/

The Telos Alliance

1241 Superior Ave. Cleveland, OH 44114 USA
+1 (216) 241-7225

For Telos Support:

24/7 telephone: +1 (216) 622-0247
Email: support@telosalliance.com
Web: telosalliance.com/support-request

Table of Contents

1	<i>Introduction</i>	<i>1</i>
	Hx1 Hybrid	1
	Purpose	1
	Features	1
	Hx2 Hybrid	3
2	<i>Installation</i>	<i>5</i>
	Next installation steps are:	5
	2.1 Connecting your telco lines	5
	2.2 Studio Audio Connections	6
	Mix-Minus	6
	Using a modern broadcast console's mix-minus capability	6
	Using a small mixer	7
	Using a production-style console	8
	Phones and Remotes	8
	2.3 Hx2 Internal Mix Minus.	10
	2.4 Input Audio Connection	11
	2.5 Output Audio Connection.	12
	2.6 Remote Control	12
	2.7 Connecting Your Hx to other systems and non-standard lines	14
	Connect to a Telos 1A2 Interface.	14
	Connect to a Telos Direct Interface Module	15
	Connect to other systems? Contact Telos Support	15
	2.8 Quick Basic Test	15
	2.9 Power Input and Grounding Safety	16

3	<i>Operation</i>	17
	3.1 Front Panel Buttons	17
	3.2 Line Status Display	17
	3.3 Metering	18
	3.4 Basic Operation	19
4	<i>Configuration Settings</i>	21
	Send Audio Processing	21
	Sample Rate Conversion	21
	High-Pass filter	21
	Send Automatic Gain Control / Limiter	21
	Receive Audio Processing	22
	Ducking System	23
	Signal Flow and Audio Processing	23
4.1	Rear Panel DIP Switch Control	24
	Dynamic Digital Equalization Configuration settings	24
	Ducker Configuration settings	25
	Receive AGC and Noise Gate Configuration settings	25
	Auto-Answer Configuration settings	26
	Send extra gain to caller configuration setting	26
	Hx2 Internal Mix-Minus Configuration setting	26
	Feedback Reduction enable	27
	Reserved bit	27
4.3	Country Specific Configuration Settings	27
	Factory Default Configuration Settings	31
5	<i>AES I/O OPTION</i>	33
	5.1 Installation Instructions	33
	5.2 AES Channel Assignment	35
	AES OUTPUT SAMPLE RATE CLOCK	35
	5.3 Restoring an AES equipped unit to analog operation	35
6.1	On-board Diagnostics	37
	6.1.1 Software Version	37
	6.1.2 DIP Switch Status	37

6	<i>Troubleshooting</i>	37
	6.1.3 T1 Test - 400 Hz Tone Generation	38
	6.1.4 T2 Test - Studio Loopback.	38
	6.1.5 T3 Test - Feed Through Test	39
	6.2 Hardware Repairs	39

7	<i>Specifications</i>	41
	7.0 Specifications	41
	ANALOG INPUTS.	41
	ANALOG OUTPUTS.	41
	AUDIO PERFORMANCE	41
	AES Digital Input / Output (Optional plug-in module)	42

8	<i>Warranty</i>	43
----------	-----------------	----

A1	<i>Telephone Terminology Guide</i>	A1
-----------	------------------------------------	----

A2	<i>Quick Reference Guide: Rear Panel Switches</i>	A19
-----------	---	-----

A3	<i>Quick Reference Guide:</i>	A21
-----------	-------------------------------	-----

Creating the Most Exciting and Engaging Audio Experiences Imaginable

Congratulations on your new Telos Alliance product!

The gang here at Telos is committed to shaping the future of audio by delivering innovative, intuitive solutions that inspire our customers to create the most exciting and engaging audio experiences imaginable.

We're grateful that you have chosen audio tools from Telos® Systems, Omnia® Audio, Axia® Audio, Linear Acoustic®, 25-Seven Systems®, and Minnetonka Audio®. We're here to help you make your work truly shine. We hope that you enjoy your Telos Alliance product for many years to come and won't hesitate to let us know if we can help in any way.

The Telos Alliance

1 Introduction



Hx1 Hybrid

The Telos Hx1 is a single digital hybrid in a 1RU 19 inch rack mount enclosure. It embodies a state of the art approach to interfacing an analog POTS (Plain Old Telephone Service) line for broadcast on-air use. The fast, precise digital automatic-nulling hybrid allows smooth, natural, conversation without speakerphone-like up-cutting effects, or the audio distortion and feedback problems often experienced with lesser hybrid interface devices.

The Hx1 implements a number of features in the digital domain in order to enhance “real-world” performance. In particular, the hybrid includes a sophisticated automatic gain control in both the send and receive paths, a carefully implemented override ducking system, a pitch shifter for feedback reduction, and a digital dynamic EQ that keeps audio spectrally consistent from call to call.

Purpose

The Telos Hx1 or Hx2 broadcast telephone hybrids are designed to deliver pure caller audio with as little leakage from the (announcer’s) send audio as possible. Telos uses state of the art digital techniques to perform the hybrid function – the subtraction of the send audio from the received caller audio. The fully digital approach assures consistently good trans-hybrid loss, audio levels and sound quality with varying telephone line conditions.

Features

The Telos Hx1 and Hx2 hybrids include many features that have historically been “add ons” or options. See the list below.

- ◆ A high-pass filter reduces hum and low frequency noise. High- frequency noise above the telephone frequency range is also attenuated.
- ◆ A smart digital Automatic Gain Control (AGC) smooths output levels. The gain changes occur naturally, delivering consistent levels without processing artifacts. A settable noise gate/expander on the receive path reduces phone line noise during caller pauses.
- ◆ An adjustable override function allows ducking of the caller while the announcer is speaking.
- ◆ Feedback is reduced by a special “pitch shifting” arrangement while echo is reduced with a basic Acoustic Echo Canceler.
- ◆ Fixed or adaptive EQ helps to correct deficiencies in a callers telephone set or the network, resulting in a clearer, warmer, more intelligible sound from the caller.
- ◆ Front panel metering is provided for input and output levels. EQ gain changes are displayed in real time.
- ◆ Auto-Answer capabilities with a selectable ring count allows for unattended operation.
- ◆ Worldwide disconnect signal detection allows use of the hybrid in different countries and with various PBXs.
- ◆ The Hx is equipped with a complete diagnostic system for system set-up and check-out.
- ◆ Optional AES3 support is available.
- ◆ Built-in universal power supply and rack mount design aids in a professional installation.
- ◆ The Hx has built-in full remote control capability, including outputs for “line ringing” and “hybrid in use” indicators.
- ◆ Telos “Status Symbols” provide clear visual cues to operators.



Hx2 Hybrid

The Telos Hx2 unit consists of two identical digital hybrids in a single 1RU 19 inch rack-mount enclosure.

The Hx2 can operate as two fully independent hybrids or be configured with an internal mix-minus to couple the two hybrids, sharing a single mix minus from the audio console and allowing callers on both hybrids to hear each other and your talent.

The Hx may be controlled remotely via connections available on the unit's remote connector (DB-9). Control functions include remote on and off control, and available status outputs include "line ringing" and "hybrid in use" open-collector indications. The remote connector allows easy direct connection to 1A2 interfaces, consoles or other remote control devices.

The unit can be equipped with an optional AES3 module, which plugs into the motherboard and converts the XLR connections from analog to AES3.

2 Installation

The Hx1 and 2 mount in a 1RU space in a standard 19" rack. The unit generates very little heat and needs no special attention for cooling or rack placement. The unit will operate in any environment where the stirred air temperature around the unit is between 0 to 40 degrees Celsius (32 to 104 degrees Fahrenheit) with a relative humidity of 0 to 98% (non-condensing).

Next installation steps are:

- ◆ Connect your telco circuits and connect a "looped through" telephone set, if desired.
- ◆ Connect Audio with analog connections (or AES3 if equipped).
- ◆ Connect any needed parallel GPIO for remote control operation or to use any of the available status indications present on the rear panel DB-9 connector.
- ◆ Power up the Hx and do a quick basic operational test using the factory settings.

This installation section covers all of the above. After completing these steps you'll be ready to move on to configuration for your specific situation.

2.1 Connecting your telco lines

The Hx1 & 2 use standard RJ-11 type "modular" telephone connectors. Only the two center pins that carry the analog line's "tip and ring" are used. Connect the telephone line using the rear panel "LINE" jack.

The Hx is designed to work with ordinary "loop start" analog phone lines, though it can operate on PBX extensions and VoIP Analog Terminal Adapters (ATA's). Hybrid performance and system behavior on these kinds of lines may vary. If you plan to use your Hx on any of these types of lines or connect your unit to other legacy Telos systems such as the 1A2 interface or the Direct Interface Module and others, please see section 2.7.

Lines that carry "Shared Line DSL" can be problematic. It's suggested that you avoid using the Hx on lines that carry DSL, but if you must use one, be sure to use a "line splitter" or DSL filter in series with the "LINE" jack on the Hx. DSL lines have data carriers above the voice band of the circuit, usually from 25 khz to 1004 khz. DSL filters strip away the high frequency data carriers and pass on the 0-4 khz voice band and signaling. Some filters are better than others and sometimes better results can be obtained by cascading several filters, each rolling off more of the high frequency energy. On a line with DSL you might hear more "hiss" and "hash" than with a normal line.

An analog phone set may be plugged into the "PHONE" jack. The telephone can be used when the Hx is "off". You might want to disable the telephone's ringer if you are in a studio environment. The Hx has a "line ringing" open collector output that you can use to light lamps or strobes. See Section 2.6: the "remote" connector.

The Hx has an "auto-answer" function that you can enable. See section 4.1.

2.2 Studio Audio Connections

Mix-Minus

The Hx must be fed send-to-caller audio that is free of the caller audio, a ‘mix-minus’. A mix-minus is a mix of all of your audio sources that will be placed on-air (or recorded) except the caller audio – thus the mix-minus designation. The European term M-1 (mix minus one) is perhaps a clearer term. A mix-minus is also sometimes referred to as a ‘clean feed’. The important thing to remember is that the hybrid must not ‘chase its tail’ – the condition when its output makes its way somehow back to the input.

Hot Tip

Many hybrid installation problems are caused by an inadvertent signal path which creates a loop from the hybrid’s output back to its own input. Some consoles allow this when certain control combinations are selected by the user. In some cases, it may be as simple a mistake as assigning the hybrid to whichever bus is feeding the hybrid. This is the first place to look when strange or erratic performance is experienced. The quickest test is to bring up only the hybrid in question on the board and select a line. Dial tone should not appear on the send meter of the hybrid in question.

Using a modern broadcast console’s mix-minus capability

Most modern broadcast consoles have provision for multiple mix-minus busses. The best consoles allow selective feeds to the phone system. This is useful since sometimes you want only one microphone feeding the phone, but sometimes you want to three or four mics (during the morning show, for instance), and sometimes you want to play some audio piece that callers need to hear and react to such as contest sound effects, etc. Some even provide for separate ‘on-air’ and ‘off line’ (recording) telephone modes.

‘Making do’ with an older console

Consoles made before around 1990 rarely had good support for mix-minuses, and almost never for more than one or two. With one of these oldsters, some clever improvisation is going to be needed. Here we describe a possible scenario that can be used as a starting point for your situation. We assume an older console with Program and Audition as the main busses. There is another bus of some kind that can be adapted for mix-minus application. We’ll call this the ‘Utility’ bus. All sources, including the hybrid, will be assigned to Program, so the audience can hear them, as usual. We will also assign most of these sources to Utility as well, just never the fader with the *hybrid’s own audio*.

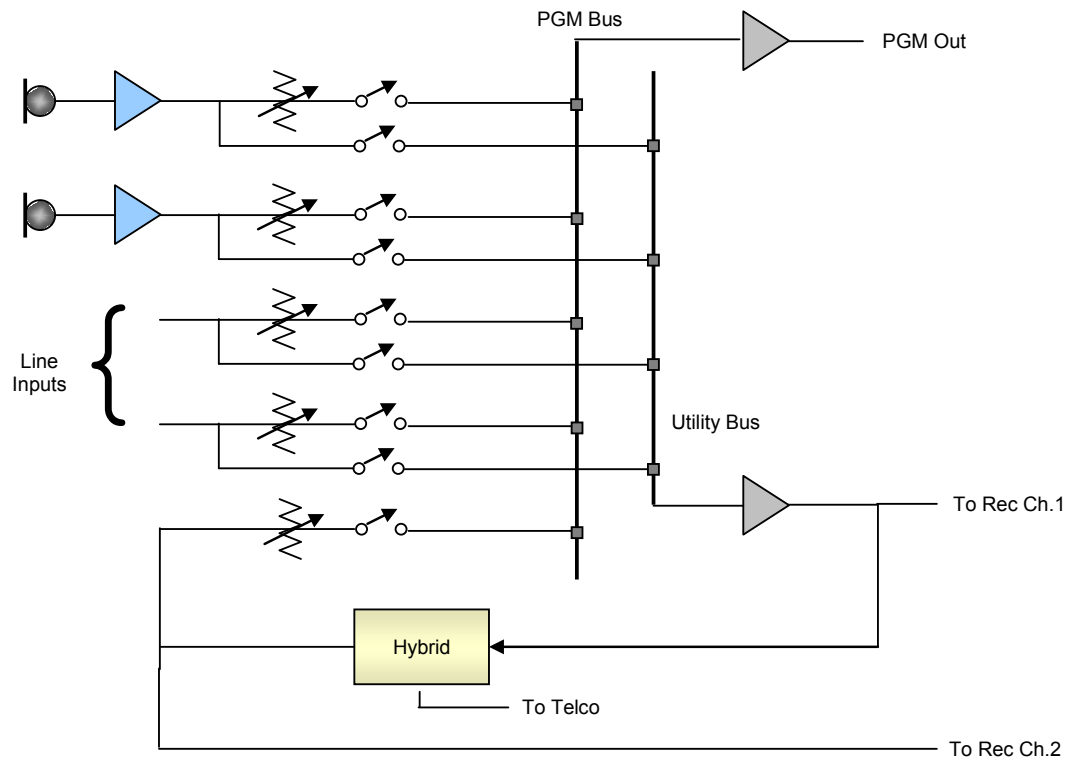

This arrangement is flexible, allowing the operator to place any or all sources in Utility for the caller to hear. In our example we have the fortunate case that the console permits the Utility bus to be fed pre-fader, letting the announcer easily use the telephone system for off-air conversations.

A recorder can be attached to the Utility and hybrid outputs to record announcer + phone audio. This is often done as shown here, with each signal to a separate track. A drawback is the potential for the operator to accidentally put the hybrid in Utility, in which case it is no longer a mix-minus. To avoid this error, the signal path could be permanently disconnected by removing the summing resistors, or some such creative operation.

If no bus is available to feed the Hx, you could use an external mixer that bridges the microphone inputs to achieve the same effect.

The Hx2 has multiple hybrids and works best if two faders can be assigned to the telephone system with two associated mix-minuses, one for each telephone line. This is probably not going to be easy with an older console. But the Hx2 has an option to work with a single external mix-minus by making an internal cross-connection of the hybrids. See Section 2.3 for more on this.

Using a small mixer

A small audio mixer is used to record interviews off the telephone line using a single hybrid. The mixer's main bus is fed to the recording device. Both the microphone and the hybrid will be brought up on the faders so the interview can be recorded.

Most small mixers (such as those made by Mackie) have one or two Aux send busses, so we will use these to feed the telephone system. We will turn up Aux for the microphone but we will make sure it is turned *fully off* for the each channel that has the corresponding *caller* audio.

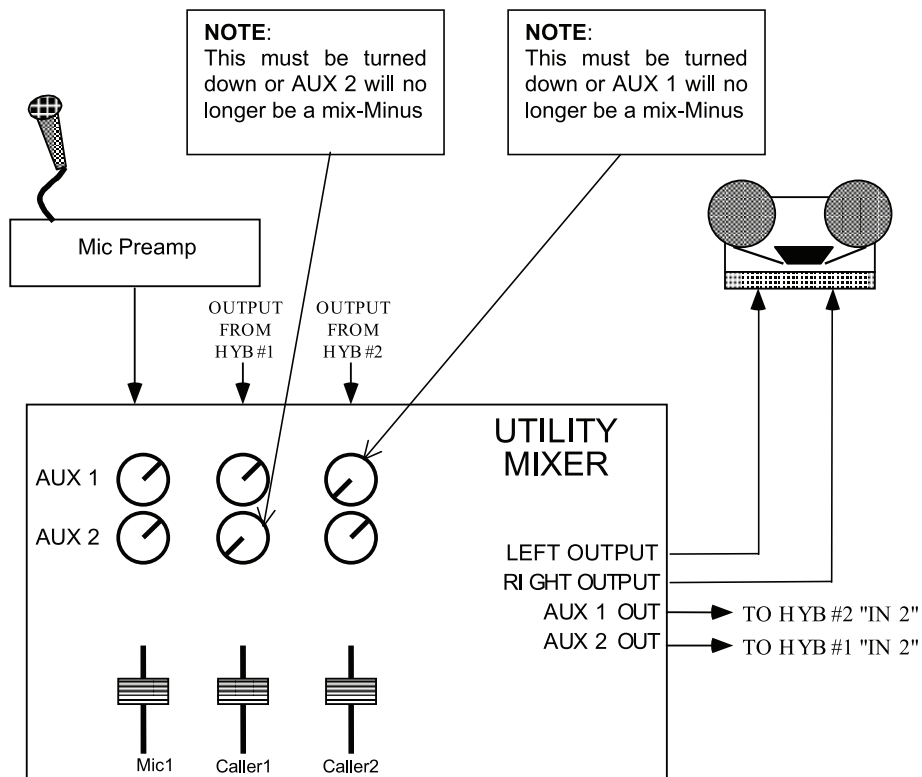
**IMPORTANT:**

Before connecting your Hx hybrid to any utility mixer, make sure to disable Phantom microphone power (if so equipped) from the mixer's mic preamp. Voltage from Phantom power will damage your Hx hybrid. Factory repairs for units damaged by Phantom power will not be covered under your unit's new-product warranty.

Using a production-style console

The Production-style consoles often used for TV audio will have multiple Aux send busses that can be used in a similar way to the small mixer example above. Each hybrid is sent from an Aux bus and everything the caller needs to hear is mixed into that bus, taking care to keep the hybrid itself off the bus.

Phones and Remotes

When on remote, to save money and hassle, calls are usually received at the studio, rather than at the remote site. In this situation, caller audio must be fed to the remote talent so that they can hear and respond to callers. Moreover, the callers need to hear the talent. In many cases, the remotes are sufficiently distant that talent cannot monitor the station for the caller feed. Even if they could, the profanity delay would be a problem, since the talent needs to hear the callers pre-delay.

All perceptual codecs (such as the Telos Zephyr or X-Stream) or any IP codec, have too much delay for talent at remote locations to hear themselves via a round-trip loop. Therefore, another mix-minus is required to feed a codec.

The talent hears callers via the codec return path. As before, you feed this return with mix-minus: a mix of everything on the program bus minus the remote audio. As for the second half of the equation, the callers hear the talent because the remote feed is added to the telephone mix-minus bus. This is no problem if you have a set-up that permits selective assignment to the hybrid mix-minus.

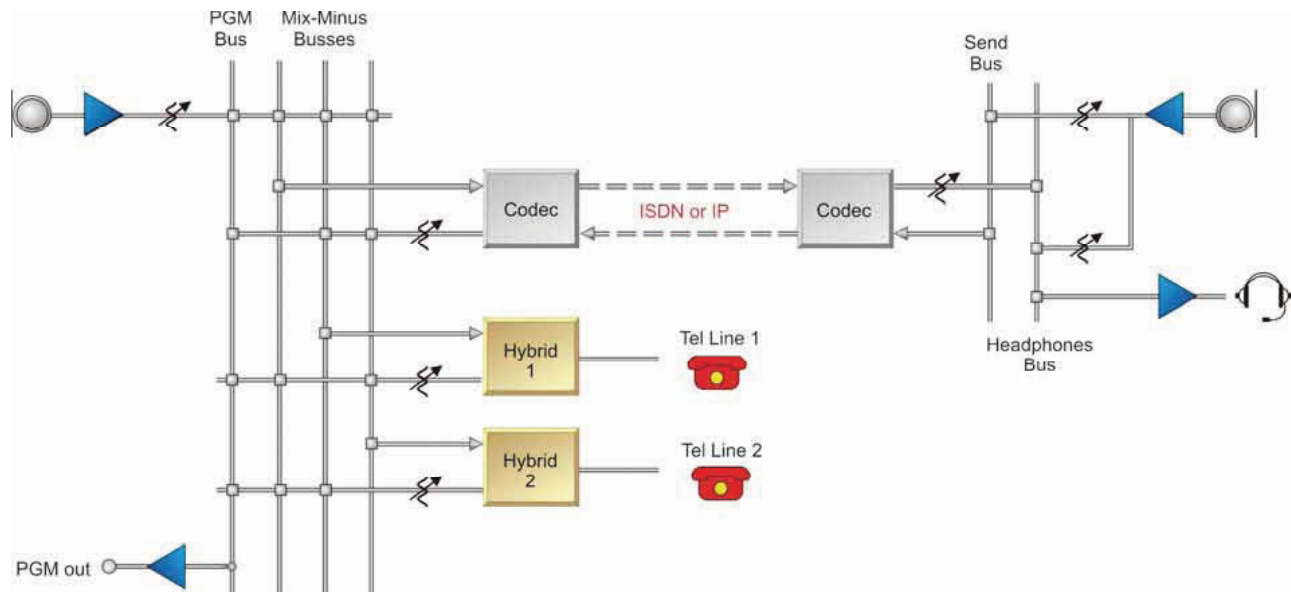

Diagram showing system set-up for remotes with delay in the transmission path and calls taken at the studio.

A problem with this arrangement is a result of a hybrid with too much leakage combined with the system delay. If the hybrid isn't doing a good job of preventing the send audio from leaking to its output, the special remote send mix-minus is corrupted. Remember, if any of the announcer audio from the remote site is returned via the monitor feed, it will be delayed by the digital link, causing an echo effect. The Telos Hx really shows its stuff in this situation. Because it has such good trans-hybrid loss, leakage is not at all likely to be a problem. And should there ever be a problem, you can solve it by increasing the amount of ducking. See Section 4.2.

Note

The Telos Hx has the more common pin-outs used for three pin XLR inputs & outputs. You can easily remember the correct signals when wiring connectors using the phrase "George Washington Bridge." Pin 1 = G = Ground, Pin 2 = W = "+" = White (typical color in mic cable, if there is no white there will be a red conductor), and Pin 3 = B = "-" = Black.

2.3 Hx2 Internal Mix Minus

The two hybrids in the Hx2 unit may be configured so that a single mix-minus feed may be used for both hybrids, with each hybrid's output fed into the other's input internally at unity gain (so that the callers can hear each other) and sums each with the audio from the consoles mix-minus output. Only the SEND IN #1 input is used to feed both hybrids.

Both hybrid outputs still function independently. The two hybrid outputs are NOT summed together, so you should provide a fader for each hybrid. The consoles mix-minus must be configured so that no hybrid's output gets sent to its own input.

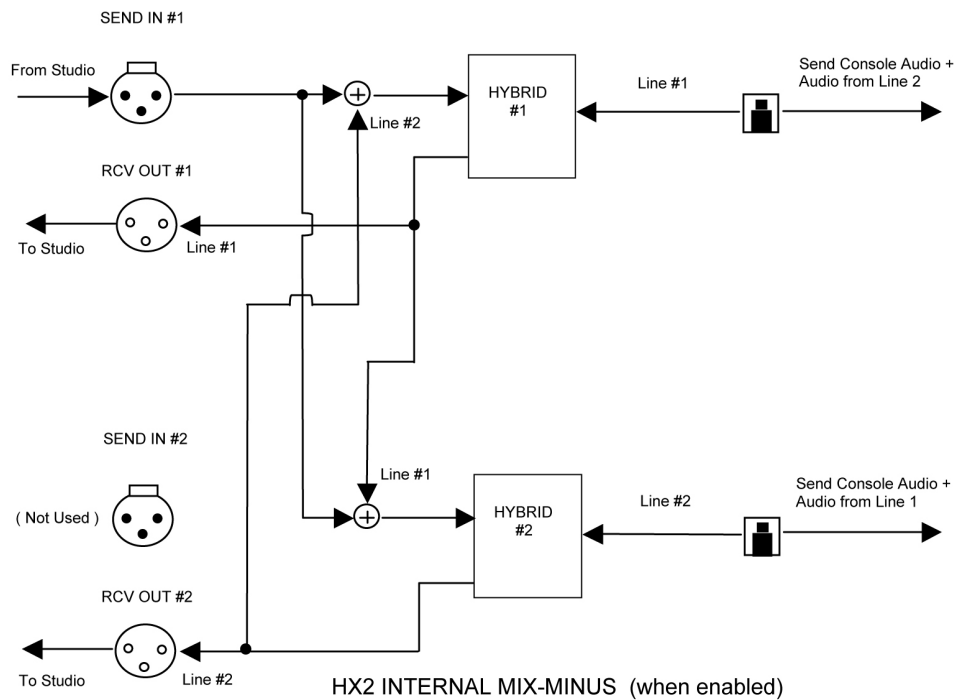

The figure above illustrates which signals are combined together inside the Digital Signal Processor and routed to each connector when the Hx2 internal mix-minus feature is enabled.

Use this option if you only have a single mix-minus available from your console and you wish to use both hybrids to conference callers on the air. You'll still need a fader for each hybrid output.

Bit #6 in the 'OPTIONS' DIP switch bank controls the mix-minus feature. The internal mix-minus feature is enabled when the switch is ON. The default factory setting is OFF - Disabled.

2.4 Input Audio Connection

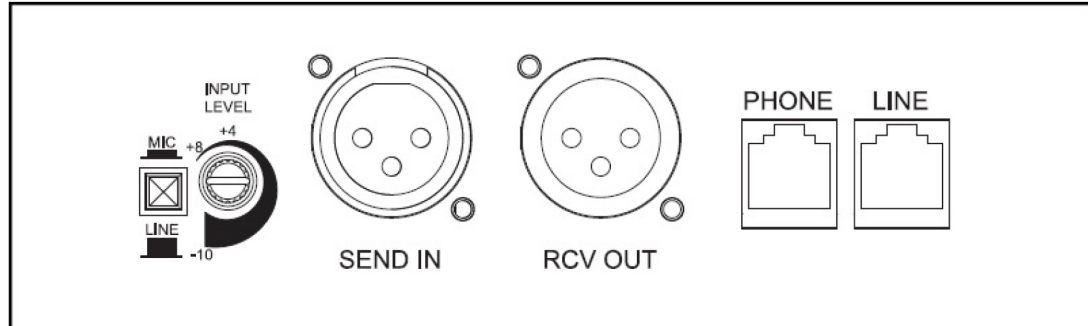

The input connection, SEND IN, has the following characteristics:

- ◆ XLR Pin 1 = Ground,
- ◆ XLR Pin 2 = High (Active Balanced, RF suppressed)
- ◆ XLR Pin 3 = Low (Active Balanced, RF suppressed)
- ◆ Bridging impedance, > 100K Ohm
- ◆ Analog clip point at +24 dBu
- ◆ Analog-to-Digital converter resolution of 24 bits
- ◆ Adjustable input level from -10 to +8 dBu
- ◆ Switchable LINE and MIC level input range

The unit can accommodate a line input level between -10 dbu and +8 dBu, adjustable with a trim pot on the rear panel. The input level is set to +4 dBu level from the factory. A +4dBu signal fed into the SEND IN connector should light the Yellow LED bargraph segment on the Front Panel.

If more input gain is needed, turn the trimmer CLOCKWISE to increase the gain to match the operating level of the hybrid.

Increasing the send level beyond a normal meter reading does not increase the level into the telco line due to the hybrid's AGC and limiting. You will only add distortion and degrade the hybrid's performance. There is a dip switch configuration option that applies an extra 3dB gain after the AGC, should you need more send level.

Next to the input level pot is a pushbutton switch that selects between line and mic levels. When the pushbutton switch is in the LINE position (out), the input range of the SEND IN signal is -10 to +8 dBu. When the switch is in the MIC position (in), the input range of the SEND IN signal is -70 to -52 dBu.

The inputs are designed to be sourced from balanced lines. Usually shielded cables have the shield wire connected only on one end (most often the input) to prevent ground loops. Older equipment with a transformer output stage may need a terminating resistor across pins 2 and 3 to maintain a proper "flat" frequency response; consult the manual for your equipment for how to use it with high impedance inputs.

If you are connecting a device with an unbalanced output to your Hx, connect the shield from the output of your device to pin 1 (ground) on the Hx input, and the "hot" lead from your unbalanced output to pin 2 (high) on the Hx. Depending on the device, you might also want to

try connecting pin 3 of the Hx input to ground, or even “floating” the ground and using only the high and low pins on the Hx. It’s also important that unbalanced lines be kept short to avoid hum and noise pickup. You’ll probably need to adjust the input gain on the Hx to match the output of your device. We also suggest that all of your audio equipment be powered from the same AC power source or circuit to prevent ground loops due to the use of multiple grounds. For complete information and suggested wiring and grounding techniques for your studio or recording workstation, please visit the support page at the Telos website: <http://www.telos systems.com/support>.

2.5 Output Audio Connection

The output connection, RCV OUT, has the following characteristics:

- ◆ XLR Pin 1 = Ground,
- ◆ XLR Pin 2 = High (Active Balanced, RF suppressed)
- ◆ XLR Pin 3 = Low (Active Balanced, RF suppressed)
- ◆ Output impedance, < 60 Ohms
- ◆ Analog clip point at +24 dBu
- ◆ Digital-to-Analog converter resolution of 24 bits

The nominal output level is fixed at +4 dBu, with +20 dBu headroom to account for the crest factor of some audio signals.

If you are connecting the output of your Hx to a device with an unbalanced input, connect the shield from your device’s unbalanced input to pin 1 (ground) on the Hx, and the “hot” lead from your device to pin 2. It’s important that unbalanced lines be kept short to avoid hum and noise pickup. We also suggest that all of your audio equipment be powered from the same AC power source or circuit to prevent ground loops due to the use of multiple grounds. For complete information on suggested wiring and grounding techniques for your studio or recording workstation, please visit the support page at the Telos website: <http://www.telos-systems.com/support>.

2.6 Remote Control

The female DB9 connector on the Back Panel provides access to control functions. Pin 1 of the DB9 connector is Ground. Pins 2 through 5 on the top row are for GPIO input signals from the remote device, while Pins 6 through 9 on the bottom row are GPIO output signals to the remote device. Two of the GPIO input pins and two of the GPIO output pins are reserved for each hybrid as follows:

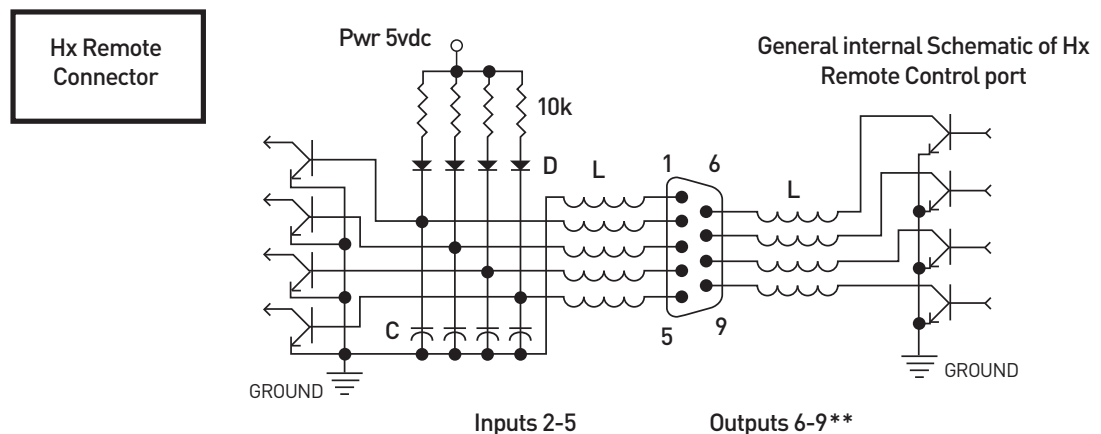

** Please review manual for current limitations per GPIO outputs

**EXAMPLE
INTERFACE
OPTION**

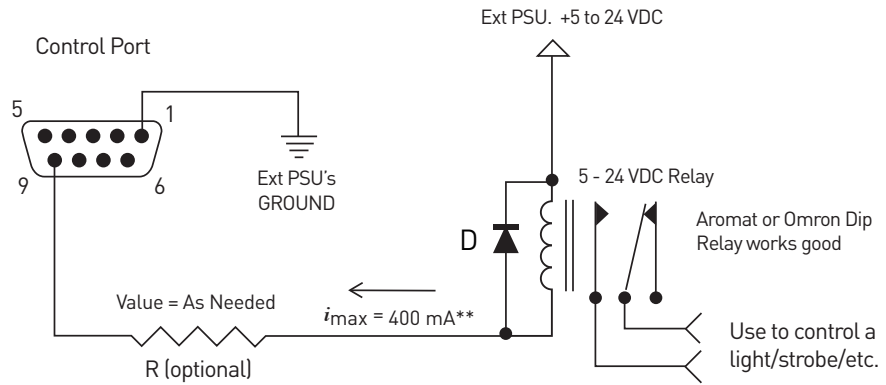

Contact Closure Out

Pin No.	Function
1 GPIO	Ground
2 GPIO IN	Hybrid #1 - Hybrid ON
3 GPIO IN	Hybrid #1 - Hybrid OFF
4 GPIO IN	Hybrid #2 - Hybrid ON
5 GPIO IN	Hybrid #2 - Hybrid OFF
6 GPIO OUT	Hybrid #1 - ringing indicator
7 GPIO OUT	Hybrid #1 - ON/OFF status indicator
8 GPIO OUT	Hybrid #2 - ringing indicator
9 GPIO OUT	Hybrid #2 - ON/OFF status indicator

A typical wiring example for an external ringing indicator

Use an external PSU and tie the ground of PSU to pin 1 of HX's Remote Port

** Please review manual for current limitations per GPIO outputs

Input Characteristics

- ◆ The GPIO inputs are designed to be universal. They accept either a voltage source up to 24VDC, or a closure to ground, which may be provided by switches, relays, or logic outputs. In the latter case either 'totem-pole' or open-collector will work. The inputs are active low.
- ◆ A built-in 10k Ohm pull up resistor is provided.

Output Characteristics

- ◆ Open-collector to ground.
- ◆ These will require a pull-up resistor to drive TTL-style logic inputs. Most equipment has the pull-up built into the input, but if there is no pull-up, you'll have to add one, connecting it from the output pin to a +5V source. An appropriate value is 2.2K Ohms. The diagram above provides a sample circuit.
- ◆ Sink (pull-down) current must be limited to 400mA maximum per output with total output restricted to 1 amp (250 mA each output if all four will be used).

The GPIO output pins can be used to provide status information to other devices or warning lamps. Outputs are available to indicate "hybrid in use" and "line ringing".

2.7 Connecting Your Hx to other systems and non-standard lines

We know that you're creative and that we couldn't hope to address every possible situation that you face, and armed with a little knowledge about how the Hx works internally, you should be successful with most applications of the Hx.

In short: The Hx will operate on anything that electrically "looks like a POTS telephone line".

You can connect the Hx to anything that is designed to run a standard Analog telephone set.

It needs loop current of 15-120 ma at 12-50 volts to run its line interface chip. The chip provides telephone line audio and line signaling status (on hook/off hook/ringing/loop drop, etc) to the processor to control the unit. If loop current isn't present, you'll have no audio and the Hx will simply hang up. This is correct behavior.

Connect to PBX's and VoIP Analog Terminal Adapters (ATA's)

When connecting to VoIP ATA's or PBX station ports, and even telephone company provided "pair gain" systems and channel banks, sometimes things can be a little different.

Odd voltages, strange feature implementations and other issues can cause problems with audio performance and produce weird behavior. Fortunately these kinds of interfaces keep getting better, meaning that the Hx will probably "just work", with a few possible exceptions.

The most common issue is likely to be what we call disconnect supervision: that is "what the line does when the caller on the line has hung up". Disconnect supervision is especially important if you intend to use the auto-answer feature!

When an "on-air" connected call drops, a wide range of things might happen:

- ◆ Most PBX's will simply drop the audio from the outside line and perhaps send a fast busy (or reorder) tone. The Hx will stay off hook until you manually drop it unless you've set the Call Progress Tone Disconnect to disconnect after hearing reorder tone with the internal dip switches.
- ◆ Some PBX's will send a momentary loop current interruption that will cause the Hx to release from the line (the desired behavior. Congratulations! You're a winner!) We've had good luck with PBX's from Avaya (Larger systems). EON/Cortelco, NEC and station disconnect supervision can be enabled in Mitel digital PBX's though it is not by default. Most telephone company central office lines do support Calling Party Control (CPC) or loop current interruption based disconnect.
- ◆ Most ATA's used by VoIP providers will simply play you reorder (fast busy) tone. Most are capable of sending the CPC loop current interruption signal, though many have this feature disabled by default. It can usually be turned on through the web interface on the unit. The best ones that we've seen are units made by Cisco/Linksys and Sipura.
- ◆ Some Foreign Exchange or 'choke' lines will not pass the CPC signal and the line will go silent or to dial tone, a reorder, or even a recorded message. This is mainly a function of circuit design and the selection of central office equipment by the telephone company.

Connect to a Telos 1A2 Interface

Our earlier products, like our classic 1A2 interface didn't support disconnect supervision for callers "on air". When using the Hx with a 1A2 interface, all features will work normally though a caller selected to be "on air" who hangs up will cause the Hx to release the line (or "go on-hook"). Audio is muted because the Hx has disconnected the line. The lamp on the switch

console and any key phones will remain lit until the line is “dropped” by the user.

You can easily build a control cable to go between the 1A2 interface and the Hx that connects the on, off and ground signals. Then plug your analog line into the “main” (hybrid #1) or “conf” (hybrid #2) jack on the 1A2 interface, as appropriate.

1A2 Interface DB-9 PIN	Hx Hybrid DB-9 PIN
5 (#1 hybrid off)	3
9 (#1 hybrid on)	2
6 (Ground)	1
4 (#2 hybrid off)	5
3 (#2 hybrid on)	4

Connect to a Telos Direct Interface Module

Using the Hx, or any hybrid supporting disconnect supervision with the Direct Interface Module (DIM) requires an external source of loop current. The DIM provides only a “dry” transformer audio feed which worked well with the simpler hybrids of the time. Visit the Telos website or contact support for several options that will allow you to use the Hx with the DIM.

Connect to other systems? Contact Telos Support

Telos collects and shares what we learn about “real world” telephony with our customers. Our customers come up with creative ways to use our products and often create elegant solutions for unusual problems. We’d appreciate hearing about your successes and challenges to share with other colleagues and friends. We’re also interested in your experiences with service providers and telecom systems and equipment vendors.

2.8 Quick Basic Test

It’s all connected, Now it’s time to check for signs of life!

First, Power the unit up and watch it complete its self test.

If the phone line is connected properly, a “dot” should be present on the display, if a minus “-” is displayed the Hx does not detect the line voltage on the idle POTS line. Check your wiring!

If your Hx is directly connected to a phone line, press the [ON] key and dial tone should be present on the Hx’s output and RCV bargraph.

If you have your Hx connected to a 1A2 interface, press a line key on the switch console. The Hx should come on and dial tone should be heard on it’s output and seen on the RCV bargraph. Pressing the ‘drop’ key should release it, and the ‘hold’ key should put the line on hold. The display will show a minus “-” to indicate that a line is not detected. This is because the 1A2 interface only routes a line to the Hx when one is selected by the user, and is present.

Verify correct mix minus operation at this point by noting that the RCV bargraph shows the dial tone at a nominal level, and that the SND bargraph shows only the microphone or audio present on the device feeding the Hx SEND IN. The goal of a proper mix minus is to prevent the hybrid from ‘hearing itself’.

2.9 Power Input and Grounding Safety

2.9 Power Input and Grounding Safety. The AC input connects mains power to the unit with a standard IEC power cord. The power supply has a universal AC input, accepting a range from 100 to 240 VAC, 50-60 Hz, at 0.15 - 0.075 Amps.

IMPORTANT SAFETY INFORMATION

Surge Protection

Precautions should be taken to prevent damage caused by power surges.

WARNING

The Hx1 and Hx2 use a universal-input power supply, which has an internal fuse. Hazardous voltages may still be present on some of the primary parts even when the fuse has blown.

The power cord is the primary disconnect mechanism. Mains power should be near the equipment and easily accessible. The unit should not be positioned such that access to the power cord is impaired. If the unit is incorporated into a rack, an easily accessible safety disconnect device should be included in the rack design.

Grounding

This equipment is designed to be operated from a power source which includes a third grounding connection in addition to the power leads. Do not defeat this safety feature. In addition to creating a potentially hazardous situation, defeating this safety ground will prevent the internal line noise filter from functioning.

Should you replace the power supply module in the future, be sure to re-connect the safety ground wires as shown in the illustration below.

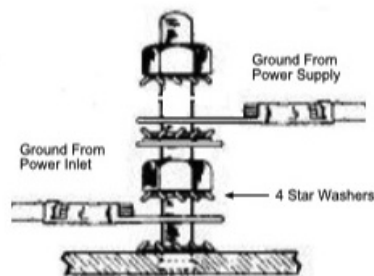

Inside the chassis near the power inlet is a ground stud. The ground wire from the power inlet is attached to the ground stud with a star washer on either side of the wire terminal. (See above figure). A nut is used to independently tighten the inlet ground wire to the chassis. Next, the ground wire from the power supply is fastened to the ground stud with a star washer on either side of the wire terminal. An additional nut is fastened to the top of the ground stud.

3 Operation

3.1 Front Panel Buttons

There is a column of three pushbutton switches on the Front Panel for each hybrid.



Hybrid ON



Caller ON-HOLD



Hybrid OFF

3.2 Line Status Display

The Line Status display on the Front Panel shows the state of the phone line in iconic form. The Status Symbol icons displayed on the LED matrix in normal operating mode are as follows:

Line is ready for incoming or outgoing calls

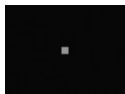

Line not detected



Line is ringing



Call is ON-AIR



Call is ON-HOLD



If the Line Status display indicates “Line not detected” after power-up, the telephone line is not connected to the LINE jack on the back Panel, or line voltage is not detected. Check your wiring and verify that dial tone is present on the line. This function is not compatible with ground start lines or trunks as these do not have loop current or voltage present until the line has been grounded momentarily or is ringing.

3.3 Metering

Each hybrid has its own SND and RCV meters to simultaneously display the studio input audio level, as well as the output level of the caller. Set the input level pot so that 0dbu on your console causes the Hx to display a yellow bar on the SND bargraph. The meter displays audio before any processing.

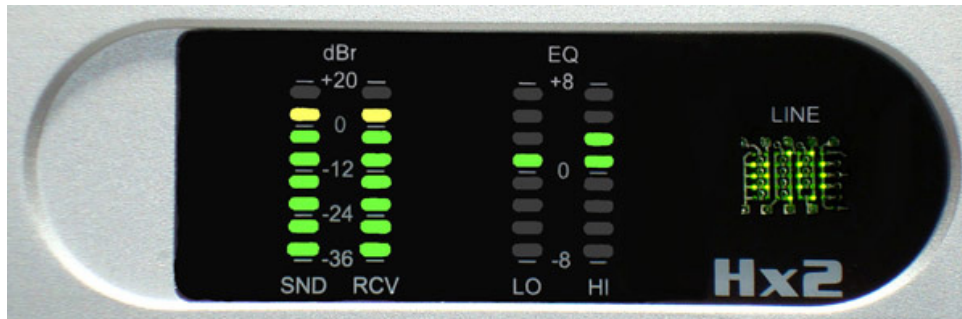

The output meter indicates audio levels after all processing and EQ. It's also useful for troubleshooting mix minus and other audio issues. A yellow bar corresponds to +4dbu at the audio output. The nominal output level is fixed at +4dbu.



Each hybrid also has a pair of EQ meters which show that amount of gain adjustment applied to the incoming caller audio in HI and LO frequency bands. **When the DDEQ feature is disabled via the Back Panel DIP switch settings, nothing will appear on the EQ HI and EQ LO bar graphs.**



3.4 Basic Operation

You can use a telephone set to either dial an outgoing call or to talk to an incoming caller before they are switched to the hybrid.

When a call is ringing-in, the line status icon will display expanding concentric squares. Push the  button to answer it directly on the hybrid or use the telephone set to speak with the caller. You can move the call from the telephone to the hybrid by pressing the  button. The telephone set will be disconnected.

When a call is taken on the hybrid, a brief mute/adapt period provides an opportunity for the system to adapt to the line before the call goes on the air. The caller hears a “noise burst” to alert him that he’s on the air but the noise burst isn’t heard by the audience as the output is muted while the noise is being sent. While the caller is on the hybrid, the hybrid continuously adapts to telephone line characteristics.

Press the  button to return the call to the telephone handset and disconnect it from the hybrid. Hang up the phone if you want to drop the call.

When a call is active on the hybrid, pressing the  button mutes the receive audio, but keeps the call active on the hybrid. The caller hears send audio while waiting on hold and the unit will disconnect if the held caller hangs up or is disconnected for any reason. When a call is on hold and you press the  button, the caller audio is restored. The caller will hear the adapt noise/ tone, about half the length of when you press the  button from any other condition. Thus, one purpose of the Hold function is to allow a “pre-adaption” to the telephone line and a quick take of it later.

4 Configuration Settings

Configuration of the Hx is done via DIP switch settings. There's a quick reference guide in the back of this book that lists the remote connector pin numbers and all of the available configuration options and their switch settings. You'll probably use those two pages more than anything else in this manual. There's also a diagram at the end of this section that shows inputs, outputs, controls and metering points. A picture is worth a thousand words, maybe more when you're in a hurry.

Before we lose you to the "quick reference guide" we should point out that here we provide the details that you might need to set up your Hx most effectively. If this is your first Hx, a few minutes with this section will help you determine which features will help you in your particular application.

Send Audio Processing

The Hx1 and Hx2 hybrid's send-to-caller audio processing consists of the following functions:

- ◆ Sample rate conversion
- ◆ High-pass filter
- ◆ Anti-Feedback - the "pitch" shifter and Acoustic Echo Canceler
- ◆ Send AGC/Limiter

Sample Rate Conversion

AES and analog input sources are sample rate converted to the hybrid's internal sampling rate of 8 KHz.

High-Pass filter

A high pass filter with a 300 Hz break frequency improves hybrid performance and enhances intelligibility by removing unnecessary low frequencies from the input audio. This function is always enabled.

Send Automatic Gain Control / Limiter

The AGC helps maintain consistent audio levels to the caller. This function is always enabled. At moderate levels it is 'AGC-like' while at higher peak levels it is more 'limiter-like'. In addition to making levels more consistent to callers, it performs the protection limiting required to meet Telecom regulatory requirements.

Feedback Reduction

The HX has a simple Acoustic Echo Canceler (AEC) that improves feedback performance and cancels echo caused by 'speaker to mike' acoustic coupling. The HX also uses a 'frequency shifter' (a Telos innovation) that inserts a small, unnoticeable, shift in frequency to the send audio to prevent feedback buildup when the system is used with open speakers.

Receive Audio Processing

The Hx1 and Hx2 hybrid's receive audio processing consists of the following functions:

- ◆ High-pass “hum” filter
- ◆ Adaptive Echo Cancellation
- ◆ Automatic Gain Control
- ◆ Noise Gate
- ◆ Digital Dynamic Equalization
- ◆ Sample rate conversion

High-pass “hum” Filter

This filter removes hum and other unwanted low frequency noise from the caller audio. This filter has a break frequency of 100 Hz.

Adaptive Echo Cancellation

An adaptive filter removes studio send audio from the received caller audio. It adapts continuously and naturally.

Receive Automatic Gain Control

The Hx's smart gated AGC improves the consistency of the caller's audio level delivered to the studio console, without audible processing ‘artifacts’.

An important additional feature of this AGC is that it is cross-coupled to other sections of the hybrids and can therefore reliably distinguish between caller audio and hybrid leakage. This allows a more aggressive gain control for bringing up low-level callers while still preserving excellent hybrid performance.

Noise Gate

Turning on the noise gate enables the built-in downward expander. The downward expander reduces low level line noise when no caller audio is present and reduces low level leakage. This function is cross-coupled with the AGC and the ducking system.

Digital Dynamic Equalizer

Telephone audio frequency response varies widely as many different factors can affect it (we've measured the response on a number of calls and the results were very revealing). Consequently, some form of receive equalization is desirable. The Hx's Digital Dynamic EQ process is the most sophisticated equalizer available in a broadcast telephone interface. All processing is performed in the digital domain. The Receive EQ settings control the type of equalization applied to the receive telephone audio as follows:

- ◆ Off - The caller audio is passed without modification.
- ◆ Fixed - This is a simple manual equalizer.
- ◆ Adaptive (Digital Dynamic) - This is a three band dynamic equalizer. We've chosen frequency breakpoints, time constants, and other characteristics to optimize the tonal quality of varied telephone callers. You set desired ‘target levels’ to customize the callers spectral characteristics, which are maintained from call to call.
- ◆ Adaptive + Fixed - This mode separately adds a fixed amount of additional gain to the high and low frequency bands of the three band dynamic equalizer.

Ducking System

The ducking function serves several purposes:

- ◆ Provides “aesthetic” control over the caller that many programmers prefer. Allows the announcer to “override” the caller in a way that sounds natural and appropriate.
- ◆ Reduces feedback when the Hx is used like a speakerphone in an “open loudspeaker” situation.
- ◆ Dynamically improves effective trans-hybrid loss to reduce leakage, when necessary.

When used, the Hx inserts a controlled loss (ducking) into whichever audio path (send or receive) is not active at the moment. When the caller is speaking, this loss is inserted in the announcer path, and when the announcer is speaking, the caller gain is reduced. The effect is “seesaw-like”. Normally, the gain reduction is symmetrical, but, if Feedback Reduction is enabled, the hybrid will have more ducking in the announcer-to-caller direction.

You’ll probably need more ducking when using an open loudspeaker. As noted above, ducking helps prevent feedback and reduces echo returned to the caller.

You can select how much of this effect you prefer, from Half Duplex, which makes the hybrid operate like a ‘one-way-at-a-time’ speakerphone, to Full Duplex (0dB) which disables ducking altogether. The default is -6 dB.

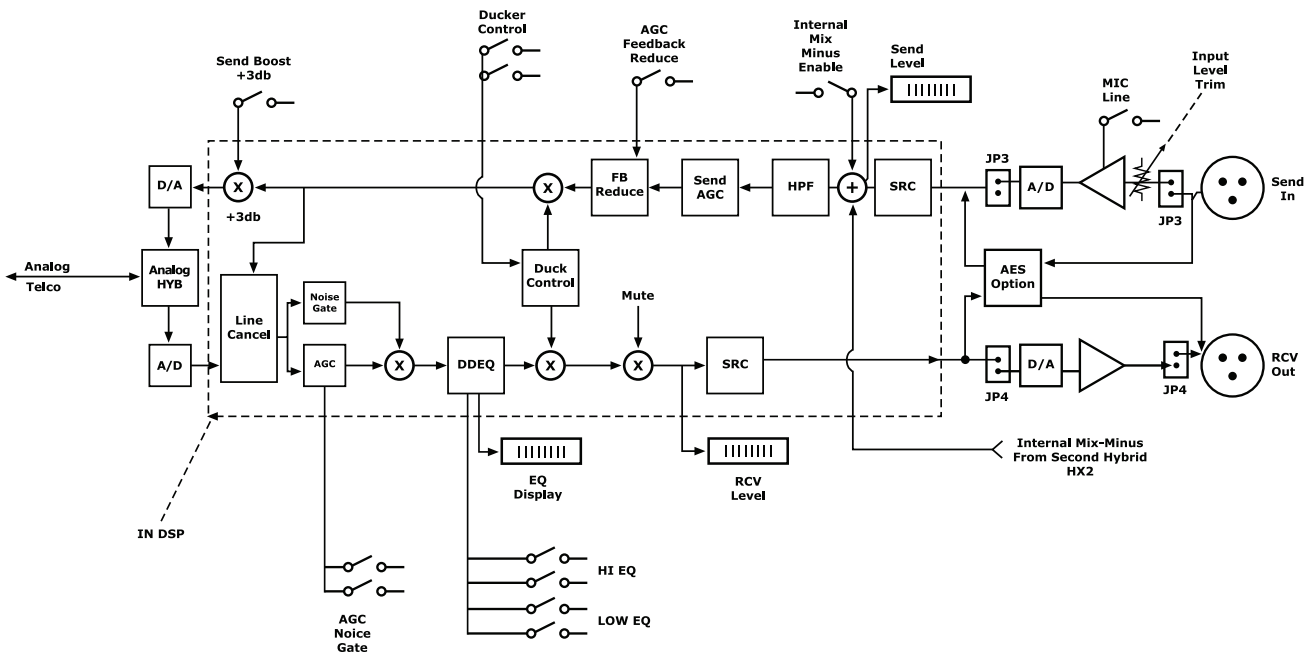

Signal Flow and Audio Processing

The above figure illustrates the signal processing chain in both the SEND input to the caller, as well as the caller receive to RCV output path. The Ducker is involved in both processing paths. The figure also shows which processing stages that you can adjust via the SETTINGS and OPTIONS bank of DIP switches in the rear of the hybrid unit. See Section 4.1 for further details regarding the DIP switch settings.

4.1 Rear Panel DIP Switch Control

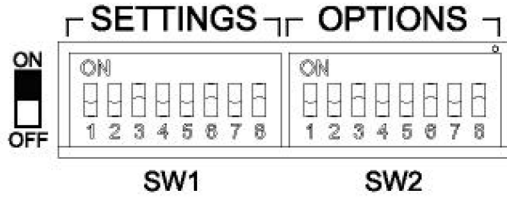

On the rear panel of the Hx1 and Hx2 chassis there are two banks of DIP switches labeled SETTINGS and OPTIONS. The SETTINGS bank of DIP switches (SW1) allows you to control the operational levels of various signal processing stages of the hybrid unit. The OPTIONS bank of DIP switches (SW2) allows you to configure the operation of various features of the hybrid. The two tables below show how the individual DIP switches are allocated on each bank.

SETTINGS	Function
Bits 1 and 2	EQ LO, fixed dB gain adjustment
Bits 3 and 4	EQ HI, fixed dB gain adjustment
Bits 5 and 6	Ducker dB gain adjustment
Bits 7 and 8	AGC and Noise Gate settings

OPTIONS	Function
Bits 1 and 2	DDEQ configuration
Bits 3 and 4	Auto-Answer configuration
Bit 5	Send gain to phone
Bit 6	Hx2 internal mix-minus enable
Bit 7	Feedback Reduction enabled
Bit 8	Reserved

Dynamic Digital Equalization Configuration settings

OPTIONS Bits #1 and #2 control the overall operation of the DDEQ processing function. You can select between OFF, Fixed EQ, Adaptive EQ, or Adaptive + Fixed EQ using the following bit settings:

OPTIONS

Bit 1	Bit 2	Configuration Setting Value
OFF	OFF	DDEQ feature is turned OFF
OFF	ON	Fixed EQ mode (Use SETTING Bits #1, 2, 3, 4 to set the levels)
ON	OFF	Adaptive EQ mode [Factory Default]

Bit 1	Bit 2	Configuration Setting Value
ON	ON	Adapt + Fixed EQ (Use SETTING Bits #1, 2, 3, 4 to set the Fixed levels)

You can separately specify the level of adjustment in the EQ_{HI} and EQ_{LO} frequency bands when the DDEQ_{mode} is configured for Fixed EQ_{mode}. SETTINGS Bits #1 and #2 control the dB adjustment for the EQ_{HI} band, and Bits #3 and #4 control the dB adjustment for the EQ_{LO} band as follows:

SETTINGS

Bit 1	Bit 2	Configuration Setting Value
OFF	OFF	0 dB adjustment, EQ _{LO} [Factory Default]
OFF	ON	+2 dB adjustment, EQ _{LO}
ON	OFF	+4 dB adjustment, EQ _{LO}
ON	ON	+6 dB adjustment, EQ _{LO}

SETTINGS

Bit 3	Bit 4	Configuration Setting Value
OFF	OFF	0 dB adjustment, EQ _{HI} [Factory Default]
OFF	ON	+2 dB adjustment, EQ _{HI}
ON	OFF	+4 dB adjustment, EQ _{HI}
ON	ON	+6 dB adjustment, EQ _{HI}

You are encouraged to try varying levels of EQ_{boost} to make your telephone audio warmer and clearer. Our factory default settings should be considered a safe starting point. Because tastes and situations differ, we don't presume to make those choices for you. Our testing does suggest that utilizing the full 6 db boost works well in most cases, dramatically enhancing telephone audio.

We suggest that you set up your phones like you would any other audio processing device: adjust and listen critically and repeat this process until you're satisfied.

Ducker Configuration settings

SETTINGS Bits #5 and #6 control the overall operation of the Ducker processing function. You can select between full-duplex (no ducking), -6 dB, -12 dB, or half-duplex (one way at a time) using the following bit settings:

SETTINGS

Bit 5	Bit 6	Configuration Setting Value
OFF	OFF	Full Duplex (no attenuation)
OFF	ON	-6 dB attenuation [Factory Default]
ON	OFF	-12 dB attenuation
ON	ON	Half Duplex

Receive AGC and Noise Gate Configuration settings

SETTINGS Bits #7 and #8 jointly control the operation of the receive AGC and Noise Gate processing functions. You can select how aggressively low level signals are brought up to the nominal (+4 dBu) level using the following bit settings:

SETTINGS

Bit 7	Bit 8	Configuration Setting Value	
OFF	OFF	Phone AGC = OFF,	Noise Gate = OFF
OFF	ON	Phone AGC = 1/2 Full,	Noise Gate = OFF
ON	OFF	Phone AGC = Full	Noise Gate = OFF [Factory Default]
ON	ON	Phone AGC = Full	Noise Gate = Normal

Auto-Answer Configuration settings

OPTIONS Bits #3 and #4 jointly control the operation of the Auto-Answer feature of the hybrid. You can select between turning the feature off, or set the number of rings before the incoming call is answered and the placed on air as follows:

OPTIONS

Bit 3	Bit 4	Configuration Setting Value	
OFF	OFF	Auto-Answer = OFF,	[Factory Default]
OFF	ON	Auto-Answer = ON,	Auto-answer after first ring
ON	OFF	Auto-Answer = ON	Auto-answer after third ring
ON	ON	Auto-Answer = ON	Auto-answer after eighth ring

Send extra gain to caller configuration setting

The Hx1 and Hx2 hybrid units have been designed to send a -9 dBu average level to the telephone line, to meet the USA's FCC regulations. OPTION Bit #5 adds 3dB of gain to the send level heard by the caller. This should only be used when the hybrid is connected to a PBX or in countries outside of the USA that permit a higher transmit level.

OPTIONS

Bit 5	Configuration Setting Value	
OFF	No additional gain is applied	[Factory Default]
ON	+3 dB additional gain is applied to the audio sent to the caller	

Hx2 Internal Mix-Minus Configuration setting

The Hx2 can operate as two independent hybrids or be configured to perform an internal mix-minus between the two hybrids.

OPTIONS

Bit 6	Configuration Setting Value
OFF	Independent: Internal mix-minus is disabled. [Factory Default]
ON	Coupled: Internal mix-minus is enabled.

Feedback Reduction enable

The Hx 1 and Hx2 has an optional Acoustic Echo Canceler in the Studio send path. This can be used when there is acoustic coupling between a loudspeaker connected to the hybrid output and a microphone connected to the input. Enabling feedback reduction also causes the ducker to insert more loss into the announcer-to-caller direction when the caller is dominant.

OPTIONS

Bit 7	Configuration Setting Value
OFF	Acoustic Echo Canceler is disabled [Factory Default]
ON	Acoustic Echo Canceler is enabled (use in "open speaker" situation)

Reserved bit

OPTIONS Bit #8 is set aside as RESERVED for future use.

OPTIONS

Bit #8	Configuration Setting Value
OFF	Reserved for future use [Factory Default]
ON	Not Recommended

4.3 Country Specific Configuration Settings

There is a third bank of DIP switches located inside the Hx chassis. This switch bank is used to set country specific voltage and line impedance settings and to set the Call Progress Tone to be detected if Call Progress Tone Disconnect is used.

The Factory Default setting is all 8 bits set to the OFF position (labeled OPEN on the switch). This default configuration is set for operation within the United States and Canada (North American telephone line characteristics, and the 'precise' dial-tone signal for Call Progress Tone Disconnect).

You must remove the top cover of the chassis to gain access to third bank of DIP switches located on the Hx motherboard. **The chassis cover should only be removed by a qualified technician. AC power must be disconnected prior to removing the cover.**

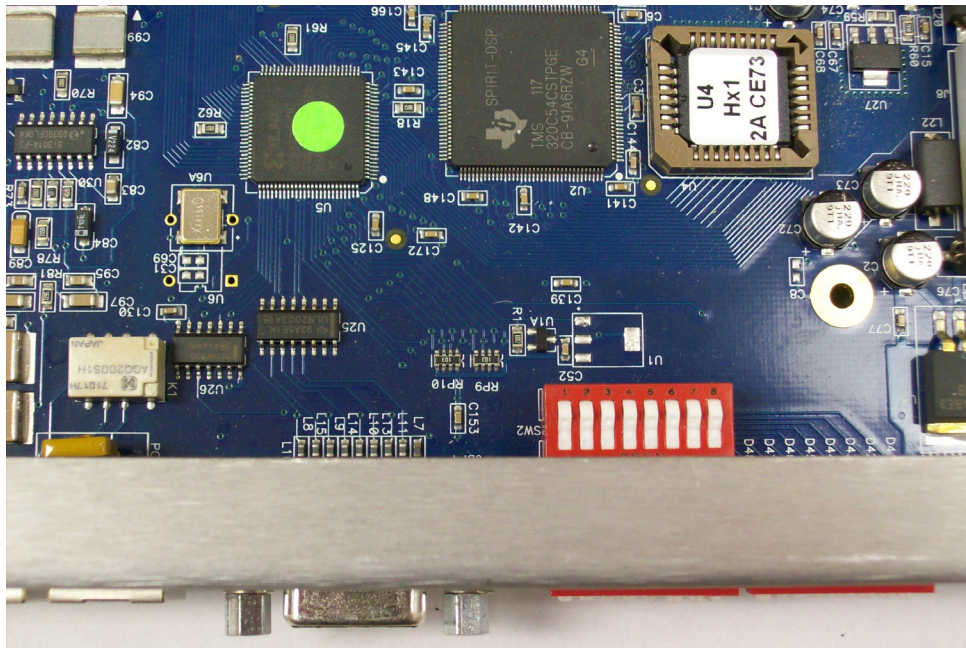

The internal DIP switch bank is divided up into two subsets of 4 switches each:

- ◆ Bits #1 through 4 configure the Hx’s telephone interface circuitry to match the telephone line impedance and voltage characteristics of the country where the hybrid is used.
- ◆ Bits #5 through 8 configure Call Progress Tone Detection to match the call progress tones used by various countries or central office switches. Call progress tones (Dial tone, busy tone, etc) can be used to make the Hx disconnect when loop current signaling is not available or is unreliable. Call Progress Tone Disconnect is active only on Auto-Answered incoming calls to prevent undesired disconnections. It may be disabled if the feature causes problems in your application. See internal DIP switch settings table below.

Table 1 lists what telephone network characteristics are being selected by Bits #1 through 4.

Table 2 lists the Call Progress Tone Detection characteristics being selected by Bits #5 through 8.

Table 3 lists the recommended DIP switch settings for each country. Reorder tone is a “fast busy” signal often used to indicate network congestion or error conditions.

Table 1 - Internal DIP Switch bank

Bit 1	Bit 2	Bit 3	Bit 4	Telephone Network
OFF	OFF	OFF	OFF	USA, Canada
OFF	OFF	OFF	ON	Japan, low voltage networks
OFF	OFF	ON	OFF	FCC compliant countries
OFF	OFF	ON	ON	CRT21, Europe (real line impedance)
OFF	ON	OFF	OFF	Custom country configuration
OFF	ON	OFF	ON	Custom country configuration
OFF	ON	ON	OFF	Custom country configuration
OFF	ON	ON	ON	Europe (complex line impedance)
ON	OFF	OFF	OFF	Custom country configuration

Bit 1	Bit 2	Bit 3	Bit 4	Telephone Network
ON	OFF	OFF	ON	Custom country configuration
ON	OFF	ON	OFF	Custom country configuration
ON	OFF	ON	ON	Reserved for future use
ON	ON	OFF	OFF	Reserved
ON	ON	OFF	ON	Reserved
ON	ON	ON	OFF	Reserved
ON	ON	ON	ON	Reserved

TABLE 2 – Internal DIP Switch bank

Bit 5	Bit 6	Bit 7	Bit 8	CPTD Signal characteristics
OFF	OFF	OFF	OFF	US dial tone
OFF	OFF	OFF	ON	US re-order signal
OFF	OFF	ON	OFF	WORLD, single freq. Dial tone
OFF	OFF	ON	ON	WORLD, Re-order, ON=155 - 550, OFF=155 - 550 msec
OFF	ON	OFF	OFF	WORLD, Re-order, ON=250 - 1200, OFF=250 - 1200 msec
OFF	ON	OFF	ON	WORLD, multi-tone dial tone
OFF	ON	ON	OFF	WORLD, multi-tone dial tone
OFF	ON	ON	ON	WORLD, pulse dial tone, ON=150 - 350, OFF=450 - 1100 msec
ON	OFF	OFF	OFF	WORLD, pulse dial tone, ON=100 - 250, OFF=200 - 400 msec
ON	OFF	OFF	ON	Reserved for future use
ON	OFF	ON	OFF	Reserved
ON	OFF	ON	ON	Reserved
ON	ON	OFF	OFF	Reserved
ON	ON	OFF	ON	Reserved
ON	ON	ON	OFF	Reserved
ON	ON	ON	ON	CPTD feature is disabled

Table 3 - Recommended Internal DIP Switch for each Country

Country	Bit 1	Bit 2	Bit 3	Bit 4	Bit 5	Bit 6	Bit 7	Bit 8
Argentina	OFF	OFF	ON	OFF	OFF	OFF	ON	OFF
Australia	ON	OFF	OFF	ON	OFF	OFF	ON	ON
Austria	OFF	OFF	ON	ON	OFF	OFF	ON	OFF
Bahrain	OFF	OFF	ON	OFF	OFF	OFF	ON	OFF
Belgium	OFF	OFF	ON	ON	OFF	OFF	ON	OFF
Brazil	OFF	OFF	OFF	ON	OFF	OFF	ON	OFF
Bulgaria	OFF	ON	ON	ON	OFF	ON	ON	ON

Country	Bit 1	Bit 2	Bit 3	Bit 4	Bit 5	Bit 6	Bit 7	Bit 8
Canada	OFF	OFF	ON	OFF	OFF	OFF	OFF	OFF
Chile	OFF	OFF	ON	OFF	OFF	OFF	ON	OFF
China	OFF	OFF	OFF	ON	OFF	OFF	ON	OFF
Colombia	OFF	OFF	ON	OFF	OFF	OFF	ON	OFF
Croatia	OFF	ON	ON	ON	OFF	ON	ON	ON
CTR21	OFF	OFF	ON	ON	OFF	OFF	ON	OFF
Cyprus	OFF	ON	ON	ON	OFF	ON	OFF	ON
Czech Repub	OFF	ON	ON	ON	OFF	OFF	ON	OFF
Denmark	OFF	OFF	ON	ON	OFF	OFF	ON	ON
Ecuador	OFF	OFF	ON	OFF	OFF	OFF	ON	OFF
Egypt	OFF	OFF	OFF	ON	OFF	ON	OFF	OFF
El Salvador	OFF	OFF	ON	OFF	OFF	OFF	ON	OFF
Finland	OFF	OFF	ON	ON	OFF	OFF	ON	OFF
France	OFF	OFF	ON	ON	OFF	ON	OFF	OFF
Germany	OFF	OFF	ON	ON	OFF	OFF	ON	ON
Greece	OFF	OFF	ON	ON	OFF	OFF	ON	OFF
Guam	OFF	OFF	ON	OFF	OFF	OFF	ON	OFF
Hong Kong	OFF	OFF	ON	OFF	OFF	OFF	OFF	OFF
Hungary	OFF	OFF	ON	OFF	OFF	OFF	ON	ON
Iceland	OFF	OFF	ON	ON	OFF	OFF	ON	OFF
India	OFF	OFF	ON	OFF	OFF	OFF	ON	OFF
Indonesia	OFF	OFF	ON	OFF	OFF	OFF	ON	OFF
Ireland	OFF	OFF	ON	ON	OFF	OFF	ON	OFF
Israel	OFF	OFF	ON	ON	OFF	OFF	ON	OFF
Italy	OFF	OFF	ON	ON	OFF	OFF	ON	ON
Japan	OFF	OFF	OFF	ON	OFF	ON	OFF	OFF
Jordan	OFF	OFF	OFF	ON	OFF	OFF	ON	OFF
Kazakhstan	OFF	OFF	OFF	ON	OFF	OFF	ON	OFF
Kuwait	OFF	OFF	ON	OFF	OFF	OFF	ON	OFF
Latvia	OFF	OFF	ON	ON	OFF	OFF	ON	OFF
Lebanon	OFF	OFF	ON	ON	OFF	OFF	ON	OFF
Luxembourg	OFF	OFF	ON	ON	OFF	OFF	ON	OFF
Macao	OFF	OFF	ON	OFF	OFF	OFF	ON	OFF
Malaysia	OFF	OFF	OFF	ON	OFF	OFF	ON	OFF
Malta	OFF	OFF	ON	ON	OFF	OFF	ON	OFF
Mexico	OFF	OFF	ON	OFF	OFF	OFF	ON	OFF
Morocco	OFF	OFF	ON	ON	OFF	OFF	ON	OFF
Netherlands	OFF	OFF	ON	ON	OFF	OFF	ON	ON
New Zealand	OFF	ON	ON	OFF	OFF	OFF	ON	OFF
Nigeria	OFF	OFF	ON	ON	OFF	OFF	ON	OFF
North Korea	OFF	OFF	ON	ON	OFF	OFF	ON	OFF
Norway	OFF	OFF	ON	ON	OFF	OFF	ON	OFF
Oman	OFF	OFF	OFF	ON	OFF	OFF	ON	OFF

Country	Bit 1	Bit 2	Bit 3	Bit 4	Bit 5	Bit 6	Bit 7	Bit 8
Pakistan	OFF	OFF	OFF	ON	OFF	OFF	ON	OFF
Peru	OFF	OFF	ON	OFF	OFF	OFF z	ON	OFF
Philippines	OFF	OFF	OFF	ON	OFF	OFF	ON	OFF
Poland	ON	OFF	OFF	OFF	OFF	OFF	ON	OFF
Portugal	OFF	OFF	ON	ON	OFF	OFF	ON	OFF
Romania	OFF	OFF	ON	OFF	OFF	OFF	ON	OFF
Russia	OFF	OFF	OFF	ON	OFF	OFF	ON	OFF
Saudi Arabia	OFF	OFF	ON	OFF	OFF	OFF	ON	OFF
Singapore	OFF	OFF	ON	OFF	OFF	OFF	ON	ON
Slovakia	OFF	OFF	ON	OFF	OFF	ON	ON	ON
Slovenia	ON	OFF	OFF	OFF	OFF	ON	ON	ON
South Africa	ON	OFF	ON	OFF	OFF	OFF	ON	OFF
South Korea	OFF	OFF	ON	OFF	OFF	OFF	ON	OFF
Spain	OFF	OFF	ON	ON	OFF	OFF	ON	OFF
Sweden	OFF	OFF	ON	ON	OFF	ON	OFF	OFF
Switzerland	OFF	OFF	ON	ON	OFF	OFF	ON	OFF
Syria	OFF	OFF	OFF	ON	OFF	OFF	ON	OFF
Taiwan	OFF	OFF	OFF	ON	ON	OFF	OFF	OFF
Thailand	OFF	OFF	OFF	ON	OFF	OFF	ON	OFF
Turkey	OFF	OFF	ON	ON	OFF	OFF	ON	OFF
UAE	OFF	OFF	ON	OFF	OFF	OFF	OFF	OFF
United Kingdom	OFF	OFF	ON	ON	OFF	ON	OFF	ON
USA	OFF	OFF	ON	OFF	OFF	OFF	OFF	OFF
Yemen	OFF	OFF	ON	OFF	OFF	OFF	ON	OFF

Factory Default Configuration Settings

These settings will work in most cases and should be considered to be a “starting point”.

The following is the Factory Default Configuration for the SETTINGS, OPTIONS, and Internal Telephone Network/Call Progress Tone Detection (CPTD) DIP switches:

	Bit 1	Bit 2	Bit 3	Bit 4	Bit 5	Bit 6	Bit 7	Bit 8
SETTINGS	OFF	OFF	OFF	OFF	OFF	ON	ON	OFF
Bits 1 and 2	EQ LO, fixed dB gain adjustment					=> 0 dB gain		
Bits 3 and 4	EQ HI, fixed dB gain adjustment					=> 0 dB gain		
Bits 5 and 6	Ducker dB gain adjustment					=> -6 dB ducking		
Bits 7 and 8	AGC and Noise Gate settings					=> AGC is FULL, Noise Gate is OFF		

	Bit 1	Bit 2	Bit 3	Bit 4	Bit 5	Bit 6	Bit 7	Bit 8
OPTIONS	ON	OFF	OFF	OFF	OFF	OFF	OFF	OFF
Bits 1 and 2	DDEQ configuration					=> Dynamic EQ is enabled		
Bits 3 and 4	Auto-Answer configuration					=> feature is OFF		
Bit 5	Send gain to phone					=> feature is OFF		
Bit 6	Hx2 internal mix-minus enable					=> feature is OFF		
Bit 7	Feedback Reduction enabled					=> feature is OFF		
Bit 8	Reserved							

	Bit 1	Bit 2	Bit 3	Bit 4	Bit 5	Bit 6	Bit 7	Bit 8
INTERNAL	OFF	OFF	OFF	OFF	OFF	OFF	OFF	OFF
Bits 1 through 4	Telephone Network configuration					=> USA, Canada		
Bits 5 through 8	Call Progress Tone Detection					=> USA dial tone		

5 AES I/O OPTION

5.1 Installation Instructions

The Hx1 and Hx2 hybrid units can be purchased with the optional AES I/O module pre-installed, or as an upgrade kit to be installed in the field. The AES board Upgrade Kit [2011-00068] includes the following items:

- 1701-00149-100(Q_{ty} =1) AES Board assembly
- 1308-00023-100(Q_{ty} =2) board standoff, M3x10mm, MF
- 1301-00077-100(Q_{ty} =2) screw, M3x6mm Phillips Pan-Head steel zinc

The following instructions explain the steps to install the AES I/O module onto the motherboard using the upgrade kit. **Chassis cover removal and upgrade kit installation should only be performed by a qualified technician or engineer.**

1. AC power must be disconnected prior to removing the chassis cover. Remove the AC power cable from the power inlet in the back of the hybrid unit.
2. Remove the 10 Phillips screws that mount the top cover to the hybrid chassis.
3. Locate the two sets of four jumpers each at both JP3 and JP4 on the motherboard. Likewise, locate edge connector JP5 on the motherboard. (See figure below). Remove the jumpers from both JP3 and JP4 and reserve them for future use if you like. (These jumpers must be re-installed if the AES I/O module is removed and the Hx is converted back to analog operation).

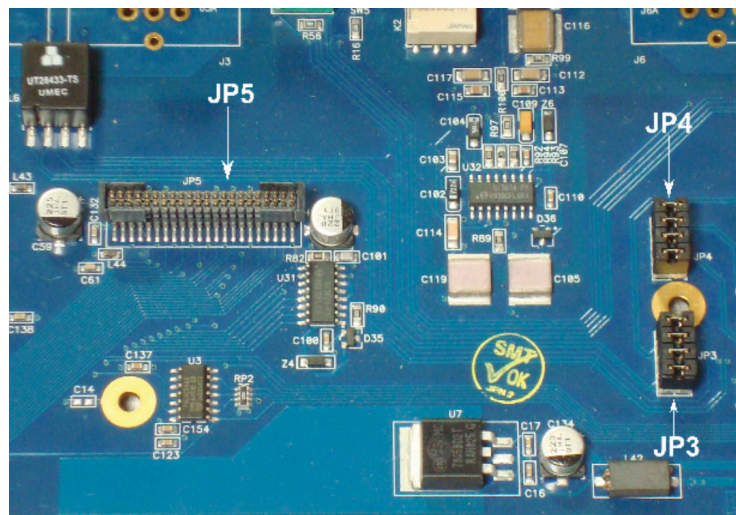

4. Locate the two gold plated mounting holes shown in the figure. Take one of the board standoffs (1308-00023-100) and screw the male end into the mounting hole located between JP3 and JP4. Take the other standoff and screw the male end into the mounting hole located below capacitor C137.

- Align connectors JR2 and JR1 on the AES plug-in module with JP4 and JP3 on the motherboard. Likewise, align connector JP1 on the plug-in module with JP5 on the motherboard. (See figure below). Push firmly to seat the plug-in module onto the motherboard. Visually confirm that connector JR2 fits onto all four sets of pins on JP4, and JR1 connector fits onto all four sets of pins on JP3.

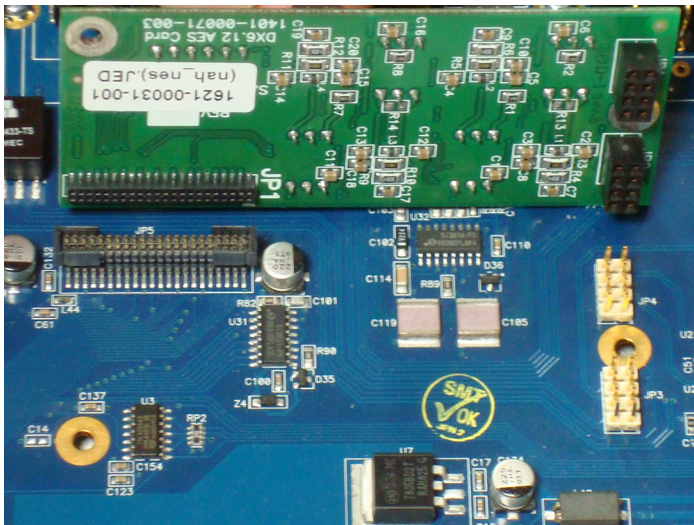

- Take the two mounting screws from the kit (1301-00077-100) and install them into the female side of the board standoffs in order to secure the AES I/O module to the hybrid motherboard.

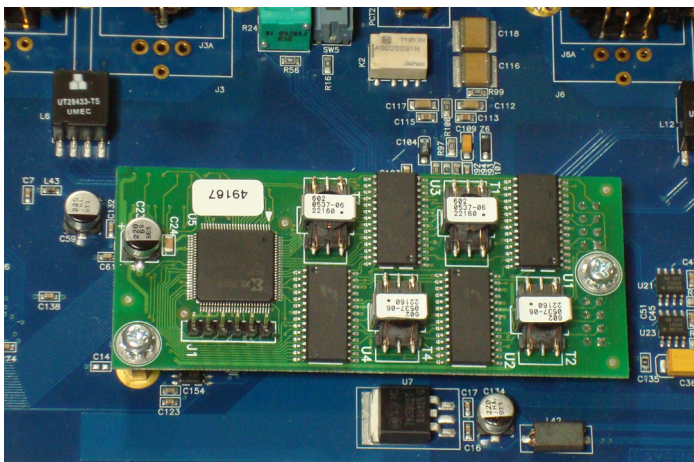

- Reinstall the top cover using the 10 Phillips screws.
- Plug the AC power cord back into the socket and wait for the unit to power up. The hybrid unit will automatically detect the presence of the AES plug-in module, and directly transmit and receive digital data at the clock rate of the AES source plugged into the SEND IN XLR input connector.
- You can use the built-in diagnostic mode of the hybrid unit to confirm that the AES I/O module is working properly. Refer to Section 6 of the User's Manual for instructions on how to enter this mode of operation. Test "T2" is a loopback test that takes audio present

at the SEND IN XLR connector and loops it back to the RCV OUT XLR connector unprocessed. The input signal and output signal levels are also displayed on the Front Panel SND and RCV LED bar graph meters.

5.2 AES Channel Assignment

Note:

The Hx1 and Hx2 use AES in mono audio mode. Connection to audio equipment configured for stereo AES audio may have unexpected results.

On the Hx1, the studio input signal should be on the LEFT AES channel feeding the SEND IN XLR connector. The studio output signal is present on the LEFT AES channel on the RCV OUT XLR connector. The RIGHT AES channel on the RCV OUT XLR will have silence.

On the Hx2, when the two hybrids are operating independently (internal mix-minus mode is disabled), the separate studio input signals should be on the LEFT AES channel being fed into the respective SEND IN #1 and SEND IN #2 XLR connectors. When the internal mix-minus mode is enabled only the LEFT AES channel being fed into SEND IN #1 is used as the studio input signal to BOTH hybrids.

On the Hx2, the studio output signals are brought out on RCV OUT #1 and RCV OUT #2 XLR connectors, so that the user has the option of using one cable or two cables. RCV OUT #1 carries hybrid 1 on the LEFT AES channel, and hybrid 2 on the RIGHT AES channel. RCV OUT #2 carries the two channels, swapped. In this way, by using two cables, the two hybrid studio output signals are available on the LEFT AES channel of the respective RCV OUT #1 and RCV OUT #1 connectors. Using one cable, both hybrid studio outputs are available from one RCV OUT connector in the AES LEFT and RIGHT channels.

AES OUTPUT SAMPLE RATE CLOCK

On the Hx1 and Hx2, the AES output sample rate clock is automatically taken from the AES input that is first present. If neither AES input is present, the AES output sample rate defaults to the internal 48Khz rate.

5.3 Restoring an AES equipped unit to analog operation

1. With power removed, remove the unit cover and the two mounting screws that fasten the AES daughter board to the main board.
2. Remove and store the AES daughter board.
3. Install 2 sets of four jumpers each on JP3 and JP4 locations on the main board. Analog audio will now be present on the rear panel XLR connectors.
4. Replace cover and verify proper operation.

7 Specifications

7.0 Specifications

ANALOG INPUTS

Send Analog Inputs	1 for Hx1, 2 for Hx2 (one per hybrid)
Connector	XLR Female, Pin 2 High (Active Balanced, RF Suppressed)
Input Range	Selectable between MIC and LINE levels
Line Input Level	Adjustable from -10 to +8 dBu
Impedance	Bridging > 50 K Ohms
Analog Clip Point	+21 dBu
A/D Converter Resolution	24 bits

ANALOG OUTPUTS

Receive Analog Outputs	1 for Hx1, 2 for Hx2 (one per hybrid)
Connector	XLR Male, Pin 2 High (Active Balanced, RF Suppressed)
Output Level	Nominal +4 dBu, fixed
Impedance	< 50 Ohms
D/A Converter Resolution	24 bits
Headroom Before Clipping	20 dB headroom from +4 dBu nominal levels

AUDIO PERFORMANCE

Frequency Response	200 to 3400 Hz, +/- 1 dB
THD+N/Input	< 0.5% THD+N using 1 KHz sine wave
Dynamic Range	Analog in to Analog out, studio loop mode, 10 hz – 20 khz A-weighted > 92 db
Signal to Noise	Analog Output, referenced to a -12dbm phone line, (producing a +4 dbu output), 10 hz-20 Khz A weighted > 72dB
Trans-hybrid loss	Analog phone line with ducking, gate, AGC, EQ all OFF relative to +4dBu input level: >55 dB

AES Digital Input / Output (Optional plug-in module)

Overview Plug-in module converts the XLR inputs and outputs to AES3 (one input or output on left channel of AES stream)

Rate Conversion Sample Rate Converters on all inputs and outputs. Inputs can accept 32, 44.1, and 48 KHz rates. Clock for outputs may be sourced from the AES inputs or internally-generated at 48 KHz

Input Level Nominal at -20 dBFs

Output Level Nominal at -20 dBFs

6 Troubleshooting

6.1 On-board Diagnostics

Pressing and holding the  button for 3 seconds puts the unit into a self-diagnostic mode. When the unit is in diagnostic mode, the Line Status display shows the current diagnostic state. This mode is only intended to provide status information, and to confirm if the hybrid unit is operational. NOTE: The left hybrid front panel buttons control diagnostics of both hybrids on an Hx2 unit.

6.1.1 Software Version

Upon entering the diagnostic mode of operation, the Line Status display should indicate the letter 'V'. The major revision number is displayed on the SND LED bargraph, and the minor revision number is displayed on the RCV LED bargraph. Simply count the number of illuminated LEDs in each bargraph for the respective version numbers. In the figure below, one segment is lit on the SND meter, and two segments are lit on the RCV meter. The software revision number shown in this figure is Version 1.2.

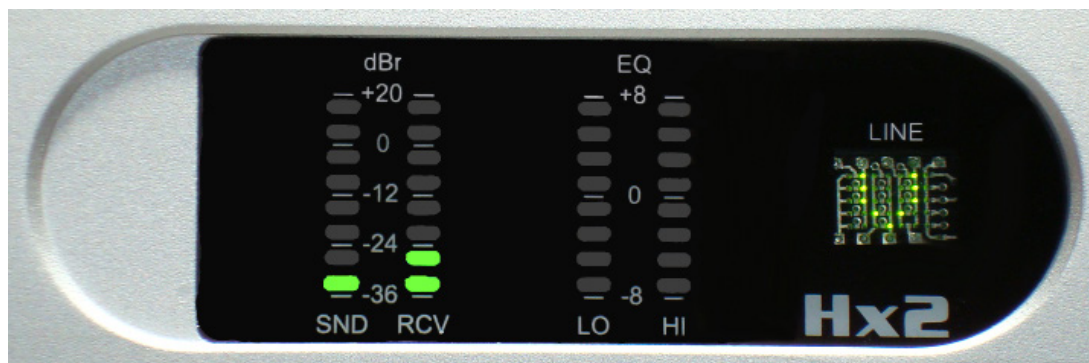

6.1.2 DIP Switch Status

Press the hybrid  button to advance to the next diagnostic test. The Line Status display should indicate the letter 'S'. The SETTINGS bank of DIP switches is displayed on the SND meter bargraph, the OPTIONS bank of DIP switches is displayed on the RCV meter bargraph, and the internal bank of DIP switches is displayed on the EQLO meter bargraph. For each bank of DIP switches, the status of Bit #1 is shown on the bottom LED segment of the bargraph, while the status of Bit #8 is shown on the top LED segment of the bargraph. If the switch is set to the ON position, the corresponding LED segment will light up. The figure below shows the Factory Default DIP switch settings. (All the bits of the internal DIP switch

bank are set to the OFF position for Factor Default setting, thus no LEDs are lit on the EQ LO meter).

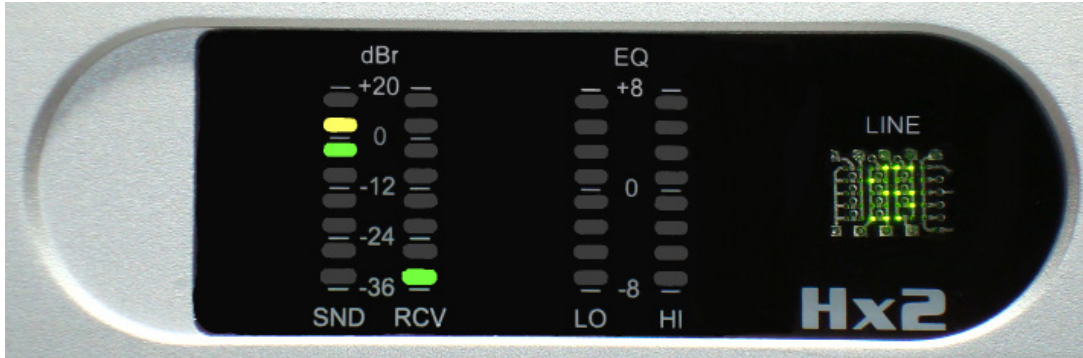

6.1.3 T1 Test - 400 Hz Tone Generation

Press the hybrid  button to advance to the next diagnostic test. The Line Status display should indicate 'T1'. The DSP chip on the motherboard generates a 400 sine wave that is sent to the RCV OUT XLR connector for each hybrid. The output level of the sine wave at the XLR is +20 dBu, and the output level should be displayed on the RCV meter bargraph. (See figure below).

The diagnostic test also takes the telephone line off-hook and outputs a -7 dBm, 400 Hz sine wave. A telephone line or line simulator must be plugged into the LINE RJ11 jack to activate the telephone interface circuitry on the hybrid motherboard. The 400 Hz tone will also be audible on the PHONE RJ11 jack, but it will be heard mixed in with the telco's dial-tone or re-order tone.

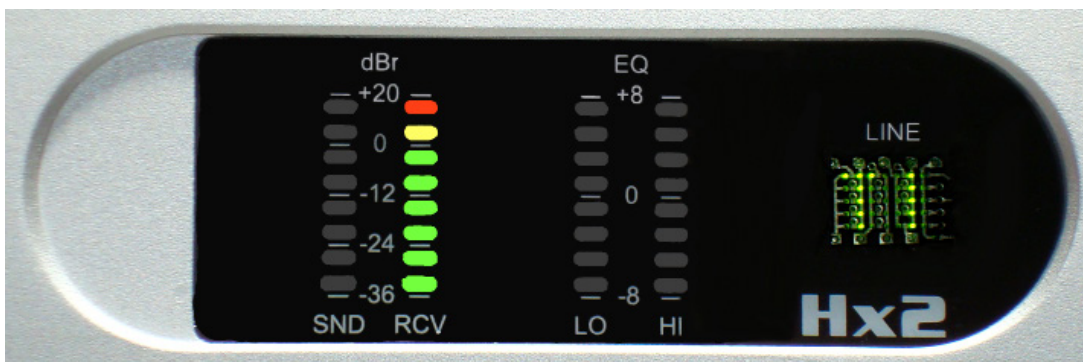

6.1.4 T2 Test - Studio Loopback

Press the hybrid  button to advance to the next diagnostic test. The Line Status display should indicate 'T2'. This test simply takes audio present on the SEND IN XLR connector and loops it back to the RCV OUT XLR connector without any processing. The loopback test works with either analog or AES inputs.

This diagnostic test can be used to adjust the INPUT LEVEL pot located in the back of the hybrid chassis. Connect a +4 dBu signal and adjust the INPUT LEVEL pot until the yellow LED segment illuminates. (See figure below).

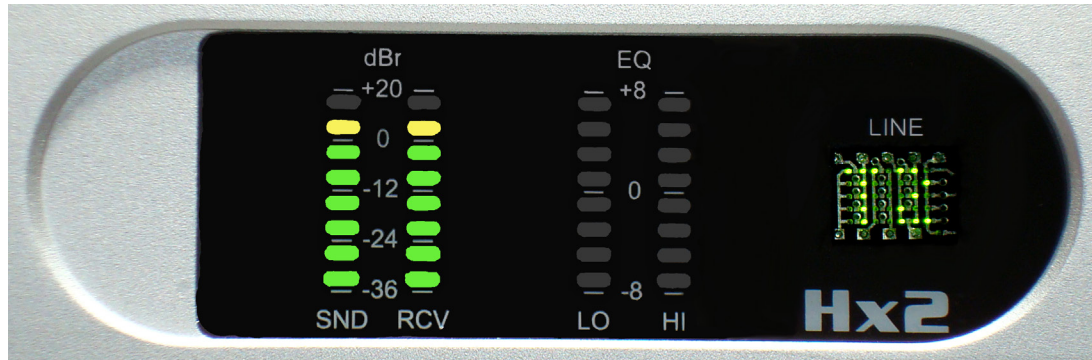

6.1.5 T3 Test - Feed Through Test

Press the  button to advance to the next diagnostic test. The Line Status display should indicate 'T3'. This test takes audio present at the SEND IN XLR connector and feeds it to the LINE RJ11 connector without any processing. Likewise, whatever signal is being fed into the LINE RJ11 connector will be routed to the RCV OUT XLR connector.

This test enables you to test the studio and telephone input and output levels. If you like, press the  button to skip past this diagnostic test. After the last test in the sequence is complete, the unit will reset itself and return to normal operation.

6.2 Hardware Repairs

A consequence of modern surface-mount construction is that it is frequently no longer possible for local repairs to be made. Special and expensive equipment is required to change parts. As well, today's equipment is complicated and requires repair technicians to have specific product experience and training and access to high-end test equipment.

At the same time, the advent of overnight delivery services means that equipment can be returned to the factory for quick turn-around repair. Therefore, we do not expect you to repair this unit at the component level, and we do not include schematics of the unit in the manual. Upon request, our support staff can fax or mail you a schematic, should you need one. Please see the first pages of this manual for proper procedures on returning units for repair.

8 Warranty



For the latest Telos Alliance warranty, visit: telosalliance.com/warranty.

A1 Telephone Terminology Guide

You'll get better results from the Telco if you understand, and speak, the lingo! We have tried to include the typical acronyms used by Telco personnel. We've put the definition under the most commonly used acronym. Telephony Technology is changing rapidly! This glossary was updated in September 2010. It will be outdated by the time the ink is dry.

The Telos website (<http://www.telos-systems.com>) is your best source of up to date information about broadcast telephony. The terms here are mainly related to Access Technologies and broadcast industry telephony common at the time of writing.

1MB – USOC term for a single Measured Business line in the US. See USOC.

1FB – USOC term for a single Flat Rate Business line in the US. See USOC.

1FR – USOC term for a single Flat Rate Residential line in the US. See USOC.

5ESS - The 5ESS Switch is a Class 5 telephone electronic switching system sold by Alcatel-Lucent. This digital central office telephone circuit switching system is used by many telephone companies. It is one of the most common Central Office switches used in the US.

Analog Terminal Adapter - a device used to connect one or more standard analog telephones (POTS) to a digital telephone system (such as a Voice over IP network) or a proprietary telephone system such as a PBX or Key System.

ADSL – Asymmetrical Digital Subscriber line. Most common type of telephone company delivered Internet access. The download/downstream direction is usually at a higher rate than the upload/upstream direction. Most often installed as “Line Share DSL”, that is the DSL “rides on top of” the POTS line. “Dry Pair DSL” is usually available for customers desiring only the data service. At the time of this writing Speeds are as fast as 7.1 Mbps down and 768kbps up, with faster speeds available soon through newly deployed technologies. Service availability is limited by loop length and cable type.

AMI – Alternate Mark Inversion. A T1 line coding method. See line coding, T1. See Also B8ZS.

ANI – Automatic Number Identification- A system, originally designed for use by Interexchange carriers (IXCs), that transmits the “billed party number” along with a call. Note that the billed party number is not necessarily the number of the line placing the call. ANI predates SS7 and can operate with analog as well as digital trunks. See also CLID and Caller ID.

Asynchronous Data - A form of serial data communication that is not clocked. To keep the bit stream synchronized, start and stop bits are added, which cuts down on throughput. RS-232 computer data is commonly asynchronous data. In contrast to synchronous data.

ATA – see Analog Terminal Adapter.

B8ZS- Bipolar 8 (with) Zero Substitution. A T1 line coding method. This is the more modern and most common line coding method of the two commonly available. See Line Coding, T1. See also AML.

Behind the PBX- This is our own term, and refers to when one privately owned phone system is tied to another privately owned phone system. The most common application is when a key system is connected to analog ports of a PBX. When it involves one PBX behind another, it is a limited Tandem application. See Tandem Switch and Tandem Tie Trunk Switching below.

Bell Operating Company. See BOC. See also RBOC. Most often called “LEC’ (Local Exchange Carrier) at the time of this writing. Few companies use the Bell name in the US any longer, though it is used in Canada.

Bellcore- BELL Communications Research. See Telcordia. The research and development organization owned by the RBOCs. Bellcore represents the RBOCs in developing standards for Telco equipment and in testing equipment compliance to those standards. Bellcore also offers educational and training programs open to all interested parties. Now Telcordia. See Telcordia.

BERT - 1) Bit Error Rate Test- A test for digital lines which involves looping a data path and sending a test pattern. Data returning is compared to the sent data to check for errors. Depending on the “Test Pattern” used, BERTs may or may not uncover problems. A line, which only has occasional problems, will need a BERT of sufficient time duration to catch that intermittent problem. A five minute BERT of an ISDN BRI circuit will only catch severe problems.

BERT - 2) Bit Error Rate Tester. The test equipment used to perform a Bit Error Rate Test.

Billing Telephone Number- The main phone number which all calls on hunt group or a PRI are billed to. This information may be required when configuring a PRI PBX.

Bit Error Rate- The basic measure of errors on digital transmission paths. It is usually expressed as the number of errors per number of bits.

Bit Error Rate Test-See BERT.

Bit Rate- The capacity of a digital channel. See Kbps.

BLEC- Building Local Exchange Carrier. A LEC who covers the occupants of a single building (or a small group of buildings) only. Often Telecom services are provided by a BLEC as a service or incentive to potential tenants. If a BLEC offers Long Distance Service it is covered by the same regulations as any other LEC.

Blue Alarm- Also called an Alarm Indicating Signal (AIS). A keep-alive signal sent if a problem occurs mid-span in a T-carrier system. The blue alarm signal is required because in some cases T-1 repeaters will become unstable if inadequate 1’s density is not maintained.

BOC - Bell Operating Company. One of the regional telephone companies that were owned by AT&T before divestiture in 1984 (i.e. New England Telephone, Ohio Bell, etc). The 22 BOCs were divided among the RBOCs at divestiture. See RBOC.

Both Way Trunks- see combination trunks.

BTN- See Billing Telephone Number.

Business Office- The part of the phone company where you call if they mess up your bill, to report problems, and to order service. Not necessarily technically literate.

Caller ID- A CLASS feature on an analog line that provides the number of the calling line as a burst of FSK data (Bell 202 modem tones) following the first ring. Also called Calling Line Identification. See also CLASS.

Calling Line ID- See CLID. See also Caller ID.

Calling Party Control- See CPC.

Call Progress Tones – Tones used in the telephone network to indicate call status or progress through the network. This includes dial tone, ring back tone, re-order (or fast busy) tone, Special Information Tones (SIT's), etc. The Telos Hx can be set to listen for these tones and disconnect when one is heard if CPC is not available or is unreliable.

CAS -Channel Associated Signaling. A bit-based signaling method used on digital lines (such as T1) that is periodically inserted into the low order bit also used for the audio transmission. See Robbed Bit Signaling.

CCIS- Common Channel Interoffice Signaling. A signaling system where network information such as address and routing information are handled externally to the actual communications (voice) path. SS7 (Signaling System 7) is the internationally standardized CCIS system. Deployment of CCIS increased efficiency since no communications (voice) channels are used merely to report an “all trunks busy” or “far end busy” conditions. It also decreased toll fraud substantially since it removed the potential for access to the signaling information that was inherent to in-band signaling schemes. CCIS also enables CLASS features as well as sophisticated re-routing features for “intelligent network” applications. See also in-band signaling. See also SS7.

Central Office- See CO.

Centrex - Central Exchange Service. An enhanced business telephone service intended to offer most of the features of a PBX but where the lines are all from the LEC out of a public switch. Offers CLASS-like features for business users such as 4-digit “inside” dialing, hold, transfer, attendant, etc.

CEPT- Conference on European Posts & Telecommunications. This is a European standards body that formerly set the standards for telephone interfaces for 26 countries.

CEPT Format- The usual rate and frame format for E1 circuits. 2.048 mbps. See E1.

CEPT Rate- See CEPT format. See also E1.

Channel Associated Signaling- See CAS. See also Robbed Bit Signaling.

Channel Bank - a device that multiplexes or demultiplexes a group of communications channels, such as analog or digital telephone lines, into one channel of higher bandwidth or higher digital bit rate, such as a DS-1 (T1) circuit. See also Pair Gain.

Choke Exchange- A telephone exchange, which is assigned to Radio and TV stations, Promoters, and other users that will be receiving large numbers of simultaneous calls. The idea is to group all of these users on a single exchange so when all routes into that exchange are in use “normal” users (on other exchanges) will not experience blocking of incoming or outgoing calls. Trunks from other local exchanges into the choke exchange are deliberately limited to just a few paths so callers will get an “all trunks busy” instead of completely blocking their local exchange. However, when one of the choke exchange users experiences a large number of calls (as when your station runs a contest) the other choke exchange users will be blocked because all trunks into the choke exchange will be busy. In the modern network, using CCIS signaling such as SS7, actual trunks are not used to convey “busy” or “all trunks busy” conditions. Thus blocking due to a station contest should not occur as the busy status in response to a call attempt is conveyed over the separate SS7 network. Therefore, the need for choke exchanges has pretty much disappeared. Nonetheless, many Telcos still insist that Broadcasters use special choke lines for call-in lines. Much of the need for the “choke network” is historical. Few current telephone company employees understand this or it’s history. They only seem to believe that it’s “required”.

Unless very aggressive contesting is planned, these arrangements should probably best be avoided. See blocking and concentration.

Circuit- A physical path through which electrical signals can pass. It consists of a network of conductors and other components, separated by insulators. Technically this term cannot be applied to fiber optic or other “non-metallic” paths. See also channel.

Circuit Switching- A system where a dedicated channel is allocated to the users of that call for the duration of that call. That channel is allocated for the duration of the call regardless if information is being transmitted at any given moment. Bandwidth through the channel is fixed, at no time may this bandwidth be exceeded. If this bandwidth is not used it is wasted. While inherently inefficient, the dependable and reliable nature of circuit switching makes it ideally suited to real-time voice and audio/video conferencing applications. When over loaded Circuit Switched networks will respond “all circuits are busy... try again later”. This is in stark contrast to packet switched networks or to systems where statistical multiplexing is used. See statistical multiplexing and Packet Switching.

CLASS- Custom Local Area Signaling Services. A variety of enhanced features (usually on analog lines) that take advantage of the ability of modern SS7 technology’s ability to transmit information about the calling party. CLASS includes such features as Caller ID, Automatic Callback, Call Trace (initiated by subscriber), Selective Call Screening, etc.

Class 4 switch - A Class 4, or Tandem, telephone switch is a U.S. telephone company central office switch used to connect local exchange (class 5) central offices for long distance communications in the Public Switched Telephone Network. See Class 4 or Class 4/5 switches,

Class 4/5 switch – Also called a “Hi/Lo” switch. This is a US telephone company central office switch that provides both local and long distance service. Many CLEC’s are configured in this way. See Class 4 or Class 5 switches.

Class 5 switch - A Class 5 telephone switch is a telephone switch or telephone exchange in the Public Switched Telephone Network located at the local telephone company’s central office, directly serving subscribers. Services provided include basic dial-tone, calling features, and additional digital and data services to subscribers using the local loop. It is considered a “local switch”.

CLEC- Competitive Local Exchange Carrier. Your local telephone service provider who is one of the new-generation providers rather than a RBOC or Independent. A CLEC is really just an independent, albeit one formed after the divestiture of AT&T. See LEC and Independent.

CLI - Calling Line Identity. European term for CLID. See CLID.

CLID- Calling Line Identification. This is the ISDN and SS7 equivalent of Caller ID; I.E. the number of the calling party. See also Caller ID and ANI.

CO- Central Office. The Telco facility to which your local telephone circuits lead. Contains “Switches” and “Trunks” as well as the local telephone circuits.

Codec- COder/DECOder. A device which takes digitized audio and “codes” it in order to reduce the transmission bit rate and which can also simultaneously “decode” such coded audio. Strictly speaking, a codec does not include an ISDN terminal adapter and related equipment. Simple codecs are also used in digital telephony. These use a simple companding scheme to reduce channel noise.

COL - COnnected Line number. European Term. The number to which you have connected. This may not be the number you dialed if call forwarding is used.

Combination Trunk- A trunk (channel) which can both make and receive calls. This generally refers to analog ground start or loop start trunks, although the term can be applied to ISDN

BRI or PRI channels as well. Each combination trunk normally has a telephone number, although they are frequently part of a hunt group and only one number may be published for that group. Also called a Both Way Trunk. This is not the same as a Two-way DID trunk. See DID trunk, Hunt Group and Trunk.

Common Channel Interoffice Signaling- See CCIS.

Competitive Local Exchange Carrier- See CLEC.

Concentration- The basic premise is to share facilities wherever possible. For instance, while there may be thousands of customers served by a given Central Office, there will be substantially less than that number of calls which can be handled simultaneously. And, even fewer long distance calls can be made simultaneously. The art of Traffic Engineering is to have enough capacity that calls are rarely blocked, but no more than that number. See also Choke Exchange and Blocking.

CPC- Calling Party Control. Sometimes referred to as “CPC Wink” or “disconnect supervision”. A call supervision feature on an analog loop start line that provides the ability for a CO (Central Office) to signal the called party when the calling party hangs up. CPC allows the PBX, key system, or telephone answering device to reset the line so that it is ready to accept or initiate another call. CPC is accomplished by either a loop current drop or reversal. With some CO equipment, it is also provided if the called party drops the call. See also MCLD.

CPE- Customer Premise Equipment- Customer owned equipment located at his/her facility, such as a CSU or terminal. In the USA and Canada, the ISDN NT1 is part of the CPE.

CPN - Called Party Number - European Term. The number that has been dialed. See Called Party Address.

CSU- Channel Service Unit. The NCTE used in the USA & Canada to terminate a T1 line. Typically the CSU must be provided by the end user. See NCTE, NIU and DSX1

CSU/DSU- A device which incorporates the functions of a CSU (Channel Service Unit) and a DSU (Data Service Unit) Most commonly it interfaces between a Switched-56 or Dedicated Digital Service circuit and a user’s data equipment such as the Zephyr.

D4- See Superframe. See also Line Format.

DCE- Data Communication Equipment. When using serial communications such RS-232, V.35, or X.21, the DCE is the device sending/receiving from the Telco line. i.e.: a modem or CSU/DSU. In contrast to DTE.

Dedicated Circuit- A permanent channel between two locations. As opposed to a Switched Circuit.

Demarc – the point of “Demarcation”. That is, where the telephone company’s responsibility ends, and the customers begins. Most often in “the main phone closet” or basement terminal. At one time, a special block was required for a Demarc, one for each customer with a simple way to disconnect the customers wiring from the Telco’s wiring at the demarc point. This has been abandoned. Most often today, when you order service, it will be “to the demarc” only, and they’ll (usually) provide a tag or “cable and pair” number so that you can locate the circuit in question. Residential phones still usually have a demarc in the form of a (usually) gray box mounted to the side of the house. It most often provides remote line disconnection facilities (for remote testing by the phone company) and a customer accessible modular jack to allow the customer to verify proper operation of the line at the side of the house, “before” the house wiring.

DID- Direct Inward Dialing. The ability for an outside caller to dial to a PBX extension without going through an attendant or auto-attendant. See also DID Number and DID Trunk.

DID Extension or DID station - A specific phone within a PBX which can be called from the public telephone network without going through an attendant or auto-attendant.

DID Number- A phone number used to route calls from the telephone network to a specific phone in a PBX (the DID extension). DID requires special DID trunks or ISDN PRI “two-way DID” trunks. Blocks of DID numbers (typically 10 or 20, sometimes higher) are purchased from the LEC or CLEC for use on the PBX. The number of DID numbers usually substantially exceeds the number of trunks in the system.

DID Trunk- A Direct Inward Dialing Trunk. A trunk (channel) which can only receive calls. A group of telephone numbers (DID numbers) are associated with a given trunk group, however there is no one-to-one correspondence between the individual channels and these numbers. The PBX uses the DID number given it by the phone company to route the channel to the correct DID extension within the PBX. This allows some or all PBX stations to receive calls directly without going through an attendant (or auto attendant). Note that there are usually more DID numbers than there are DID trunks. See DID number and DID extension.

Direct Inward Dialing- See DID.

Directory Number (USA & Canada)- Your seven digit telephone number (without the area code), as found in the telephone directory.

DMS-100 – Nortel’s very popular central office switch provides local POTS service and connectivity to the public switched telephone network. It is used widely in countries throughout the world.

DNIS- Dialed Number Identification Service- A service, typically offered by a long distance company on 800 lines, that provides the number dialed by the caller. This allows a caller to receive specific treatment depending on the number dialed.

DP - Dial Pulse. A method of sending address information by either 1) Causing brief interruptions in loop current or 2) Causing brief changes of state of a bit on a digital circuit using Channel Associated Signaling. In other words, “rotary” or “pulse” dialing. See also DTMF and CAS.

“Dry Loop” or “Dry Pair” DSL – DSL service offered without a POTS line to carry it. These circuits often cost less because many of the taxes, “regulatory recovery fees” and other nonsense charges apply only to POTS phone service. Also, many customers wish to use VoIP with their DSL and have no use for the expensive POTS phone once required to be ordered with DSL service.

DSØ- Digital Signal Level Zero. The smallest unit of measure of the standard rate hierarchy used by the Telcos (i.e. all other rates are a multiple of the DSØ rate. For example, the T1 rate is 24 times the DSØ rate and the E1 rate is 32 times the DSØ rate). 64 kbps. See also B channel.

DS1-Digital Signal Level 1. The second level up the digital rate hierarchy used by the Telcos. This is 24 times the DSØ rate for a total of 1.544 mbps. See DSØ. See also T1.

DS2-Digital Signal Level 2. Data rate of 6.312 mbps (4 times the DS1 rate). See DSØ and DS1.

DS3-Digital Signal Level 3. Data rate of 43.232 mbps (28 times the DS1 rate). See DSØ and DS1.

DSL- Digital Subscriber Line. Traditionally refers to an ISDN circuit or sometimes a T1 line, although the term is also frequently used to mean the next generation beyond ISDN. Sometimes xDSL is used to indicate that the writer is referring to any of a number of emerging DSL technologies.

DSLAM – Central Office or wire center based Digital Subscriber Line Access Multiplexer. What's on the "other end" of your DSL line. These are sometimes fed by HICAP (High Capacity or Fiber) facilities to remote wire centers ("remotes" or "vaults") where "Pair Gain" (carrier) systems reside, so that DSL service may be provided to customers who otherwise could not be served due to loop length limitations.

DSU- Data Service Unit. See CSU/DSU.

DSX-1- Digital Cross Connect level 1 (USA & Canada, primarily). Defined as part of the DS1 (T1) specification and is a closely related signal. The type of signal switched by a Digital Cross-Connect System (DACS). The FDL is stripped off at the DACS interface. DSX-1 is also the type of signal that arrives at the user side of a CSU on a T1 line. A DSX-1 cable is limited to 655 feet (200 meters).

DTE- Data Terminal Equipment- When using serial communications such RS-232, V.35, or X.21, the DTE is the device sending/receiving from a modem or CSU/DSU. In contrast to DCE.

DTMF – Dual Tone Multi Frequency. The standard tone-pairs used on telephone terminals for dialing using in-band signaling. The standards define 16 tone-pairs (0-9, #, * and A-F) although most terminals support only 12 of them (0-9, * and #). These are also sometimes referred to as "Touch Tones". Note that while digital data terminals have the same symbols, ISDN uses "common channel signaling" (over the D channel) and therefore does not necessarily generate any tones at all. However many terminals still generate the tones since they will still be used on occasion to access services (such as voicemail or automated attendant) at the far end using in-band tones. The extra 4 tones were originally used in the US military "Autovon" phone network.

E1- A common type of digital telephone trunk widely deployed outside the US and Canada. Has 31 available 64 kbps channels (called DSØ's) plus a sync/control channel for a total data rate of 2.048 mbps.

E-1- See E1.

ESF- Extended Superframe. A type of Line format supported on T1 circuits. The Telco determines the line format and line encoding of your line. See Line Format.

Exchange- Another name for a Central Office (most often used in European countries). Also used in the USA & Canada to refer to a particular 3-digit prefix of a 7-digit telephone number. See CO.

Extended Superframe. See ESF.

FDL- Facilities Data Link. A bi-directional data link available on T1 circuits when the ESF line format is used. The FDL is primarily used by the Telco to poll the CSU for error statistics.

Four Wire – A circuit path using separate pairs for send and receive. This term is also used when referring to digital channels that inherently have discrete send and receive paths, regardless of the number of pairs (or other media) used. See also Hybrid.

Frame – A unit of data which is defined by the specific communications protocol used. See Line Format, T1.

FXO – Foreign Exchange Office termination. A line or port meant to connect to the POTS output of a Central Office. Such an interface goes off and on hook to signal status and expects to receive ringing current.

FXS – Foreign Exchange Station termination. A line or port meant to connect to a telephone. Such an interface must look for current flow to know when the attached device goes off-hook. It must be able to generate ringing current. An FXS port will "run a telephone set".

Glare – On a POTS line an incoming call is signaled by periodically applying an AC ring voltage to the line. Since there is a semi random period before the ring, and pauses between rings, it is possible to seize a line which is “about to ring” (and answer a call) when attempting to place an outgoing call. When this scenario happens it is called glare. Glare is much less likely if Ground Start or ISDN trunks are used. See also Ground Start Trunk.

GR-303 - See SLC-96.

Grade of service- This is simply the ratio of calls blocked to total calls in a decimal form. Therefore, a grade of service of P.08 would represent 8% blocking. Telephone tariffs regulate the acceptable average grade of service which must be provided on public networks. See also Blocking.

Ground Start Trunk – A type of telephone trunk where the request to make an outgoing call (i.e. request for dial tone) is made by briefly grounding the Tip conductor. Many PBX system use ground start trunks as they are less prone to glare than Loop start trunks. Ground start lines are sometimes used with equipment designed for Loop Start lines. This may or may not work - generally it serves to prevent outgoing calls while incoming calls work normally. Telcos may call these “ground start lines”. See Loop Start Trunk. See also Glare.

GTD-5 - The GTD-5 EAX (General Telephone Digital Number 5 Electronic Automatic Exchange) is the Class 5 telephone switch developed by GTE Automatic Electric Laboratories. This digital central office telephone circuit switching system is used in the former GTE service areas and by many smaller telecommunications service providers. It does not support ISDN.

HDSL - High-Data-Rate Digital Subscriber Line. HDSL delivers 1.544 Mbps of bandwidth each way over two copper twisted pairs. Because HDSL provides T1 speed, telephone companies have been using HDSL to provision local access to T1 services whenever possible. The operating range of HDSL is limited to 12,000 feet, so repeaters can be installed to extend the service. HDSL requires two twisted pairs, so it is deployed primarily for PBX network connections, digital loop carrier systems, interexchange POPs, Internet servers, and private data networks. DC voltage used to power the network Interface Unit (NIU) is “phantomed” between the two pairs. See NIU.

Hunt group- A group of telephone channels configured so that if the first is busy (engaged) the call goes to the next channel, if that channel is busy it goes to the next channel, etc. Hunt groups may hunt from the highest to the lowest, the lowest to the highest, or on some other arbitrary pattern. But the order of hunting will usually be fixed, beginning with one channel and working through (“hunting”) until an unused channel is found. The term may have originated back in the old manual switchboard days when the operator literally hunted for an unused jack to plug a cord into. This arrangement is very common in business scenarios where a single incoming number (the Listed Directory Number) is given to the public, but multiple incoming channels are supported. See also LDN.

Hybrid – A device which converts from a two-wire signal such as POTS lines (or a 2-wire intercom) to a four-wire system (separate send and receive paths) such as used in the pro-audio world. While this task is theoretically quite simple, the fact the impedance of most phone lines varies widely across frequency complicates matters. The Telos 10 telephone system was the first practical DSP based hybrid and applied the then brand-new technology to this problem.

IEC -1) Inter-exchange Carrier. “Long Distance” carrier. Handles Interlata and interstate calls. Most often referred to as IXC.

IEC - 2) International Electrotechnical Committee. A European standards body best known for the power plug now used throughout the world for AC power cords for use on office equipment and computers.

ILEC – Incumbent Local Exchange Carrier. A local Exchange Carrier which entered the marketplace before the enactment of the 1996 Telecom act; i.e. a telephone company which is neither an Indi nor an RBOC. See LEC and CLEC.

IMUX – See Inverse Multiplexing.

In Band Signaling- A signaling system where network information such as address and routing information are handled over the communications (voice) path itself. Usually the information is represented in the form of audible tones, however DC loop current signaling also qualifies as In Band Signaling. See also CCIS.

Incumbent Local Exchange Carrier. See ILEC. See also CLEC & LEC

Independent – Any of the phone companies in existence at the time of divestiture that were not affiliated with the Bell System. See RBOC, LEC, and CLEC.

Indi- See Independent.

Interconnect Company- A vendor of telecommunications CPE other than a BOC or AT&T. This term was originated by AT&T and was meant to be derisive towards the fledgling industry when the courts said it was OK for end users to buy equipment from someone other than the Bell System. This industry flourished, in spite of AT&T's disdain, and ironically, the RBOCs were not allowed to sell CPE under the terms of the break up of AT&T. With the current state of deregulation, the RBOCs are slowly re-entering this business. The term is now considered archaic at the time of this writing.

Inter-exchange Carrier- See IEC.

Interwork- The ability of two different type of networks to communicate seamlessly. For example, ISDN can interwork calls to both the POTS network and the Switched-56 network.

ISDN - Integrated Services Digital Network- A relatively new and highly flexible type of telephone service which allows dialing on digital channels with multiple bi-directional “Bearer” channels each with a capacity of 56 or 64 Kbps and a single bi-directional “D channel”. See BRI and PRI.

ISDN Protocol - The “language” used for communication between the Telco’s switch and the customer’s Terminal Adapter. Each ISDN circuit has one protocol, and the protocol has no effect on where or whom one may call. See ETS 300, National ISDN, and Custom ISDN.

ISDN 2- A term used in Europe for ISDN BRI. Also called SØ. Not to be confused with National ISDN-2. See BRI.

ISDN 30- A term used in Europe for ISDN PRI. Also called S2M. See PRI.

ISG – Incoming Service Grouping. A Hunt Group. See Hunt Group.

IXC- IntereXchange Carrier- See IEC.

Kbps- KiloBits Per Second. Measure of digital channel capacity.

Key Telephone System – A system that allows multiple telephones to share multiple pre-determined telephone lines. The system provides indicators to allow the user’s to understand the status of each line available on a given phone. In its most basic form it is up to the user to provide the intelligence to select an unused line, or answer a ringing line, for example. See also PBX.

LATA- Local Access and Transport Area. The area within which calls are routed by your Local Exchange Carrier (LEC). Under the divestiture of the Bell System calls going outside of this area must be handled by an Interexchange carrier (IEC). With the latest round of de-regulation the usual IEC companies are being allowed to compete in the IntraLATA long distance market

and LECs are beginning to be permitted to handle InterLATA calls.

LDN- Listed Directory Number. When a number of Telco channels share the same hunt group, it is customary to give out only one phone number for the group, although generally each channel will have its own number. The number given out is the “Listed Directory Number” since that is the number that would be listed in the Telephone Directory and given to customers. Sometimes called a Pilot Number. See also DN and Hunt Group.

LE - Local Exchange. European term for Central Office. See CO.

LEC- Local Exchange Carrier. Your local telephone service provider which is either an RBOC or an Independent. In other words, a traditional phone company. In contrast to CLEC or IEC.

Line- An electrical connection between a telephone service provider’s switch (LEC or CLEC) and a telephone terminal or Key system. An electrical connection between a telephone service provider’s switch and another switch is technically called a trunk. Note that some type of physical lines offer more than one channel. I.E. a BRI circuit has 2 channels, called B channels. This term is a confusing one, so we try to avoid using it. See Channel. See also Station Line.

Line card- The circuit in the Telco switch to which your line is connected. On an ISDN circuit the line card performs a role analogous to the NT1 in adapting to and equalizing the circuit to establish OSI Layer 1.

Line Coding, T1- The clock signal for T1 is derived at the far end from the data bits themselves. Therefore, T1 lines have certain restrictions as to the data allowed. No more than 15 zeros shall be sent in a row; and average density of 12.5% ones must be maintained. The CSU is responsible to ensure that these requirements are met. The line encoding method, AMI or B8ZS determines exactly how these requirements are met while still allowing recovery of the original data at the far end. Your Telco will determine the method used on a specific circuit. B8ZS is preferred. E1 circuits have similar restrictions. HDB3 is preferred for E1 circuits.

Listed Directory Number- See LDN.

Line Equipment – the circuit on a telephone company’s switch that is used to provide service to a customer.

Line Encoding, T1- See Line Coding, T1.

Line Format, T1- Modern T1 circuits usually use either Superframe (sometimes called SF or D4) or Extended Superframe (sometimes called ESF) line formatting. The type of framing used is determined by your Telco. ESF is preferred. See ESF and SF.

Line Side- This is the side of a central office switch that the subscriber’s telephone lines are connected to. The main reason for distinguishing between this and the trunk side is that certain customer related features (Such as CLASS and Centrex features) are inapplicable to trunks. See also Trunk Side. The user side of a PBX. Also called the station side.

Line Termination - See LT.

Local Access and Transport Area- See LATA.

Local Exchange Carrier- See LEC and CLEC.

Long Distance- If your local US Telco is a former Bell Operating Company then any call outside of your LATA or any Interstate call is considered long distance and is handled by an IEC. The above is true regardless of whether you are referring to a dedicated line or a dial up call. However, under the current state of deregulation, toll calls within a LATA may now be covered by the IXC, and in some cases RBOCs are being permitted to handle InterLATA calls. These requirements are largely ignored at the time of this writing.

Loop- The telephone circuit from the CO to the customer's premises. Generally refers to a copper cable circuit.

Loop Current Disconnect Supervision - Another name for CPC. See CPC.

Loop Qualification- Process of actually measuring the loss on a prospective ISDN line to see if it can be used for ISDN service. The actual loss on the line (usually measured at 40 kHz) is the determining factor whether ISDN service can be offered without a repeater. Generally ISDN or DSL is available up to 18,000 feet from the serving Central Office. It may not be available within this range, or may be available further from the CO. Only a loop qualification can tell for sure. Not all Telcos will extend ISDN lines with repeaters.

Loop Start Line - A plain old telephone line. The telephone terminal signals the "off hook" condition by allowing DC current to flow. See Ground Start Trunk. See also Glare.

Loop Start Trunk - A plain old telephone line connected to a PBX switch. See Loop Start Line. The PBX signals the "off hook" condition by allowing DC current to flow. Ground Start Trunks are generally preferred for use on PBXs to prevent glare. Also, most trunks are considered "designed circuits". That means that only a specified amount of loop loss is permissible, and that the telephone company is required to deliver the trunk to the customer at a given audio level. At the time of this writing, analog trunks are rapidly becoming less common as they are expensive to design, provision and maintain. See Ground Start Trunk. See also Glare.

LOS- Loss Of Signal. An LED or other indicator that illuminates if a signal is absent. This terminology is commonly used with T-1 equipment. See Red alarm.

LT - Line Termination - The electrical and protocol specifications for the Central Office end of an ISDN line. If you wish to connect an ISDN terminal (such as a Zephyr Xstream) to a PBX the PBX must support LT ISDN. See also NT and Line Card.

Lucent Technologies- Company that made the former AT&T 5ESS switch, as well as various other pieces of Telco gear and semiconductors. Lucent was split off from AT&T in 1996. Lucent's PBX division was spun off in 2001 as AVAYA.

MCLD- Modifying Calling Line Disconnect. The parameter on the Lucent 5ESS switch that determines if CPC is active. Should be set to "Yes" if CPC is required. See CPC.

National ISDN (USA & Canada)- The US "standardized" multi-platform ISDN protocol. The first version is National ISDN-1. As of mid 1996 National ISDN-2 has been implemented in some areas and is fully backward compatible with National ISDN-1.

NCTE - Network Channel Terminating Equipment. NCTE is a general term that can be applied to a CSU or NT1 or other equipment terminating a digital line at the customer's premises. In many countries, the NCTE is provided by the Telco. The USA is not one of those countries.

Network Channel Terminating Equipment. See NCTE.

Network Termination - See NT.

NIU - Network Interface Unit, a line powered, telephone company owned, interface card that provides a remote controlled loopback function, some error monitoring and signal level conditioning. It's typically a box on the wall with some lights, that has at least one RJ45 jack, and a cable going to either the RJ21x block or other demarc. The NIU converts the incoming 2 pair line to an RJ45 T1 or PRI line, you need a CSU/DSU between it and your equipment to handle the level conversion and provide your own loopback capability. The NIU and the cable going to it are the phone company's property and their maintenance responsibility. Most often the NIU (or sometimes called simply "NI" or "Smart Jack") is located in a locked cabinet. Also a nice little college in Illinois.

Northern Telecom- The Canadian company which was once the manufacturing arm of Bell Canada (it was called Northern Electric back then). Now called Nortel Networks. See Nortel.

NT - Network Termination - The electrical and protocol specifications for the user end of an ISDN line. See also LT.

NT-1- An alternative expression for NT1. See NT1.

NT1- Network Termination Type 1. The termination at the customer premises of an ISDN BRI circuit. The NT1 performs the role of line termination of the “U” interface and Codes/Decodes from the line’s 2B1Q coding scheme. The customer end of the NT1 interfaces using the “S” or “T” interface. The NT1 is frequently part of the “Terminal Adapter” and is built-in to Zephyr Xstream, Zephyr, ZephyrExpress, Telos TWO and TWOx12 systems sold in the USA & Canada. See also NCTE.

NTBA- Network Termination Basic Access. The term used for NT1 in some countries. See NT1. See also NCTE.

OOS – Out of Service. An alarm light or condition on a T1 or trunk.

Packet Switching. Packet Switched networks are more commonly associated with Computers, Local Area Networks, and the Internet. In a packet switched network the raw stream of data is broken into individual pieces, called packets. Each packet is routed through the data network, individually. This is somewhat analogous to taking the pages of a book and sending each page as a letter through the postal system. The page numbers would allow reassembly of the book no matter what order the pages were received at the far end. The end user does not know or care that the packets may travel a variety of routes. If a given page did not arrive in a reasonable length of time, one could request that this page be re-sent. Most packet switched systems allow packets to be discarded if the network capacity is exceeded (the postal system is not supposed to do this). This is accommodated by the higher-level protocol, which knows to request that a packet be re-sent if it does not arrive. Therefore, the typical behavior of a packet switched network when overloaded is that throughput decreases (i.e. the network “slows down”) as the percentage of discarded packets increases. In stark contrast to Circuit Switched networks. See Circuit Switching.

Pair Gain - Pair gain is a method of transmitting multiple POTS signals over the twisted pairs traditionally used for a single traditional subscriber line in telephone systems. See SLC-96.

PBX- Private Branch Exchange. A privately owned switch. Basically, a PBX is a private “business” telephone system which also interfaces to the telephone network. In some circles ‘PBX’ implies a manual switchboard whereas ‘PABX’ (Private Automatic branch exchange) implies a PBX that supports dialing by end users.

PIC- Primary Interexchange Carrier. (USA) This is your default “1+” carrier used for inter-LATA calls. In some areas you may have two PICs, one for interLATA calls, and one for intraLATA long distance calls (in which case it stands for Primary Intraexchange Carrier). In some areas intraLATA long distance calls are still handled by your RBOC, in others you now have a choice. You can identify who your current PIC is by dialing 700 555-4141.

POP - Point Of Presence. The local facility where your IEC maintains a switch. This is where your long distance calls get routed so that your IEC can handle them. Also used to describe the local access point of an Internet Service Provider. Sometimes carriers maintain “Paper POP’s”, that is points of interconnection that are advantageous for regulatory reasons. These are often at Co-Location facilities (COLO’s) or “Telco Hotels”, which are large hardened data centers where many carriers and customers interconnect and terminate data and voice facilities.

Port - This is a pretty general term. Newton’s Telecom Dictionary 10th edition defines a port as “An entrance to or an exit from a network”. Many phone equipment vendors refer to ports as the

physical interface between a Switch and a Line or Trunk or “line equipment”. Product literature often refers to the number of ports on a phone system. In this context it refers to the number of phones or lines (or sometimes the combination) the system supports.

POT- Plain Old Telephone. A black, rotary-dial desk phone. Usually a Western Electric model 500 set. Outdated term.

POTS – Plain Old Telephone Service. Regular old-fashioned analog loop start phone service.

PRI – ISDN Primary Rate Interface- A form of ISDN with 23 “B Channels” and one “D channel”. All 24 channels are on a single cable. Functionally related to T1 telephone circuits. In Europe PRI has 30 “B Channels” and one “D Channel” and one “Sync channel”. See also B channel and D channel.

Provisioning -The act of configuring a telecommunications service. Also refers to the complete line configuration information.

RBOC- Regional Bell Operating Company. Most often called Local Exchange Carriers (LEC's) at the time of this writing. See CLEC and LEC.

RCF – Remote Call Forwarding, a telephone company service that provides local “virtual numbers” from distant locations. Customers are responsible for the cost of calls forwarded though he RCF number. VoIP service providers can offer similar services a greatly reduced costs since the numbers are delivered via the Internet (“backhauled”) at no cost.

RD- Receive Data. Data coming from the network, or DCE towards the DTE. Also, a light on a modem or CSU/DSU that lights to indicate presence of this signal.

Red Alarm- An alarm state on a T-carrier circuit that indicates that the incoming signal (at the network interface) has lost frame for more than a few seconds. Normally a Yellow alarm is then returned (i.e. sent back) if a Red alarm is present. A Red Alarm indicates a loss of inbound signal; a Yellow alarm indicates (indirectly) a loss of outbound signal. See also Yellow alarm, Blue alarm, and LOS.

Regional Bell Operating Company- See RBOC or LEC.

Repeater- A device intended to extend ISDN telephone service to sites further from the central office than could normally be served. i.e.: beyond 18,000 feet. ISDN repeater technologies include “BRITE”, “Virtual ISDN”, “Lightspan”, and “Total Reach”. Some Telcos do not use repeaters. Compatibility between a given NT1 (CPE) and a repeater is less certain than if that CPE were directly connected to the switch.

Robbed Bit Signaling- A signaling scheme that “borrows” bits on each T1 channel for use as signaling channels. On SF T1's there are two bits, the A bit and the B bit in each direction. On ESF T1's there is also a C and D bit in each direction, although they are rarely used. Using these bits, various older analog trunk interfaces can be emulated over a T1. For instance, dial pulse address signaling using 10 pulse per second (rotary style) digit groups over these bits. Since robbed bit signaling interferes with the least significant bit, only 7 bits can be used for sensitive data applications, leaving only a 56kbps channel for data applications. See also CAS and CCIS.

Rollover – See Hunt Group.

SDSL - SDSL is a rate-adaptive Digital Subscriber Line (DSL) variant with T1/E1-like data rates (T1: 1.544 Mbps, E1: 2.048 Mbps). It runs over one pair of copper wires, with a maximum range of 10,000 feet. It cannot co-exist with a conventional voice service on the same pair as it utilizes the entire bandwidth or the subscriber loop.

Sealing Current- Unlike telegraphy, teletypewriter and POTS lines, most digital lines (such as ISDN) use a voltage rather than current mode of operation. Sealing Current allows a controlled

amount of current to be passed through a telecom circuit for purposes of “healing” resistive faults caused by corrosion. Bellcore specifies sealing current on the ISDN U interface in the USA. The Siemens EWSD switch does not provide sealing current. Most other ISDN capable switches used in North America do.

SF- Superframe. A type of Line format supported on T1 circuits. The Telco determines the line format and line encoding of your line. ESF is the preferred Line Format on T1 circuits. See Line Format.

Silence Suppression- See Statistical Multiplexing.

SIP – Session Initiation Protocol, the most common IP protocol at the time of this writing for providing telephone service over IP facilities. It is used by most Voice Over Internet Protocol (VOIP) service providers.

SLC-96 – A Subscriber Loop Carrier Circuit system manufactured by AT&T (now Lucent). SLC-96 has its own version of T1 framing between it and the CO. SLC-96 and similar “SLIC” systems may or may not perform a concentration function. The interface is the Bellcore TR-008 or the newer GR-303 interfaces that are specialized versions of T1 intended to allow transparent transport of analog CLASS features such as Caller ID, Call Waiting, etc. The GR-303 interface is specifically intended to be used as a common point of interconnection between alternative equipment, technologies, and/or networks (i.e. voice-over-DSL, voice-over-IP, etc)) and the public switched network. See the following link for additional information from Telcordia: <http://www.telcordia.com/resources/genericreq/gr303/index.html>.

SLIC-1) Subscriber Line Interface Circuit, see “Line Card”.

SLIC-2) The equipment used with the AT&T (Lucent) SLCC Subscriber Loop Carrier Circuit, a system used to multiplex a number of subscriber loops onto a single circuit (usually a T1 circuit) to reduce fixed costs.

SLIC-3) Also sometimes used generically for other brands of similar equipment. See also SLC-96.

Smart Jack – see NIU.

SS7 - Signaling System 7. The internationally adopted Common Channel Interoffice Signaling (CCIS) system. Previous to SS7 the Bell System used SS6 which did not support the International Standards. SS7 does. It allows for substantially flexibility and power in dynamically routings calls. An SS7 database lookup is how a call to a mobile telephone user can be handled transparently despite the fact that the user’s location may change. Also used to determine what carrier should handle a given toll free call. See also CCIS.

Station Line – A telephone circuit from a PBX to a telephone on that PBX. Since this is a telephone-to-switch connection it is considered to be a “line”. See Line and Trunk.

Station Side - The user side of a PBX. The side of the switch that the telephones are attached. Also, occasionally called the ‘line side’. The main reason for distinguishing between this and the trunk side is that certain customer related features (Such as Hold and Transfer) are inapplicable to most trunks. See also Trunk Side.

Statistical Multiplexing- A method of improving effective bandwidth of a Telco channel. Statistical Multiplexing takes advantage that there are typically many pauses in a conversation. By taking advantage of this fact, and not sending the pauses, improvements in efficiency can be made. Also referred to as silence suppression. See Circuit Switched.

Subscriber- The customer of a Telecommunications company. This term dates back to when a local Telephone Company was formed at the specific request of a group of customers who agreed in advance to “subscribe” to the service.

Superframe- See SF.

Switch- Telephone switching device which “makes the connection” when you place a call. Modern switches are specialized computers. ISDN service is provided from a “Digital” switch, most commonly (in the USA & Canada) an AT&T model “5ESS”, Northern Telecom model “DMS-100”, or Siemens model “EWSD”. See also PBX.

Switched Circuit- A channel which is not permanent in nature, but is connected through a switching device of some kind. The switching device allows a switched circuit to access many other switched circuits (the usual “dial up” type of telephone channels). Once the connection is made however, the complete capacity of the channel is available for use. As opposed to a dedicated circuit or a packet based connection.

Switched-56- Archaic: A type of digital telephone service developed in the mid 1980’s which allows dialing on a single 56Kbps line. Each Switched-56 circuit has 1 or 2 copper wire-pairs associated with it. Switched-56 was replaced with ISDN, which was cheaper and more flexible, and finally by DSL and IP variants. See also CSU/DSU.

Synchronous Data- A form of serial data which uses a clock signal to synchronize the bit stream. Since, unlike asynchronous data, no start and stop bits are used, data throughput is higher than with asynchronous data. ISDN and T-1 use Synchronous data. See also Asynchronous Data.

T1- A common type of digital telephone carrier widely deployed within the US, Canada, and Japan. Has 24 64Kbps channels (called DSØ’s). The most common use for a T1 at the time of this writing is for Telephone company “access service” via an ISDN Primary Rate Interface (23 “bearer” channels and a single “Data” channel for call set up). A T1 can carry data service (or mixed data and voice) when provisioned appropriately, but lower cost services such as DSL are largely supplanting T1 circuits for Internet access.

T-1- An alternative expression for T1. See T1.

Tandem Switch- A switch which is between two others. It connects two trunks together. Long distance calls on a LEC line go through a long distance tandem that passes them through to the long distance provider’s switch.

Tandem Tie Trunk Switching- When a PBX switch allows a tie line call to dial out of the switch. For example, if switch “A” in Arkansas has a tie line to switch “B” in Boise, Boise could use the tie line to make calls from switch “A”.

TD- Transmit Data. Data coming from the DTE towards the DCE or network. Also, a light on a modem or CSU/DSU that lights to indicate presence of this signal.

Telco- Telephone Company. Your local telephone service provider. In the 21st century you generally have a choice of Telcos if you are a business in a major metropolitan area in the USA. Competition is coming to the Telecom industry around the world.

Telcordia Technologies- Formerly Bellcore. The research and development organization owned by the telephone companies. Telcordia represents the phone companies in developing standards for Telco equipment and in testing equipment compliance to those standards. Promotes competition and compatibility through standards promoting interoperability such as GR-303. Telcordia also offers educational and training programs open to all interested parties. Bellcore was sold to SAIC in 1997. Telcordia is responsive to both RBOCs and independent Telcos. Their web site is: <http://www.telcordia.com>. See GR-303.

Telephone Number- See DN and MSN.

Telos Customer Support +1.216.622.0247. Available 24 hours a day, every day. You may also ask for assistance by emailing to Support@telos-systems.com.

Tie Line- See Tie Trunk.

Tie trunk- A Trunk between two PBXs. Note, a tie line is a dedicated circuit, not a switched circuit. See Trunk.

TR-008 - See SLC-96.

Trouble Ticket-A Telco “work order” used to track Customer Repairs within the Telco. If you call someone “inside” the Telco’s repair department, they will need this number to proceed. It will also be needed whenever you call to check on the status of a repair. Always ask for this number when initiating a repair request.

Trunk- A communications path between two switching systems. Note that many trunks may be on a single circuit (if that circuit has multiple channels). The trunks most users will deal with are between the Telco switch and a PBX. However, a Tie Trunk can connect two PBXs. See also Tie Trunk and Trunk Group.

Trunk Group- A number of telephone channels which are functionally related. Most common is the Hunt Group. Other common types include Incoming Trunk Groups and Outgoing Trunk Groups. See also Combination Trunks and Two-way DID Trunks.

Trunk Side- Central Office: The side of a central office that faces the network, between switches. Historically many CO switches could not make trunk to trunk connections (as opposed to tandem and long distance switches, that are always used to connect trunks together). Hence the need to distinguish between the “line side” and the “trunk side” of the switch. See also Line Side.

Trunk Side- PBX: The side of a PBX that connects to the Telco. Historically many PBXs could not make trunk to trunk connections. Hence the need to distinguish between the “line side” and the “trunk side” of the switch. Since a trunk is a switch-to-switch circuit, these circuits can be called trunks. Beware, even though you have a PBX, the Telco may still call these “lines” (even though your PBX considers them trunks). See also Trunk and Line Side.

Two-way DID trunk- An ISDN PRI equipped for direct inward dialing. Most PBX trunks are related to a given phone number, either alone or as part of a hunt group. In the case of a “normal” (i.e. analog) DID Trunk, a group of phone numbers are associated with that DID trunk (or group of trunks) and incoming calls include the DID number, so the PBX can route that call to the correct DID extension. These are one-way (i.e. inward only) trunks. This is exactly how ISDN PRI functions, with the DID information coming in over the D channel. There is a big difference between a normal DID Trunk and a Two-way DID trunk over ISDN PRI. For one thing, ISDN PRI is digital. Another distinction is that you cannot dial out over a true DID trunk, while you can dial out over a PRI (hence the conflicting designation “Two Way Direct Inward Dialing Trunk”).

Two Wire – A circuit path where only a single pair of wires is used. A hybrid is used to convert from two wire to four wire circuits. No hybrid is perfect, and those used by the phone company can be poor. However, the hybrids in Telos Hx units are approaching perfection!

USOC – Universal Service Order Code, The Bell System Universal Service Ordering Code (USOC) system was developed to connect customer premises equipment to the public network. These codes, adopted in part by the FCC, Part 68, Subpart F, Section 68.502, are a series of Registered Jack (RJ) wiring configurations for telephone jacks that remain in use today. The now famous RJ-11 and RJ-45 came from this naming convention.

Variant- The particular protocol (i.e. National ISDN-1 or ETS 300) running on a specific switch. Not all variants are valid for a specific switch. The switch brand and model plus the variant defines the ISDN protocol. Applies to configuring the 2101. See ISDN Protocol.

Virtual ISDN- An alternative to repeaters which uses a local Telco Switch to act as a repeater and which then sends the signal onto another switch which supports ISDN. See also Repeater.

VoIP – Voice over Internet Protocol, communications services that are transported via packet switched IP networks, rather than the public switched telephone network (PSTN).

Work Order- See Trouble Ticket.

Yellow Alarm- An alarm on a T-carrier circuit that is returned by the local equipment if it is in a Red Alarm state. A Red Alarm indicates a loss of inbound signal; a Yellow alarm indicates (indirectly) a loss of outbound signal. See Red Alarm, Blue Alarm and LOS.

A2 Quick Reference Guide: Rear Panel Switches

SETTINGS	Function
Bits 1 and 2 EQ LO, fixed dB gain adjustment	
OFF OFF	0 dB adjustment, EQ LO [Factory Default]
OFF ON	+2 dB adjustment, EQ LO
ON OFF	+4 dB adjustment, EQ LO
ON ON	+6 dB adjustment, EQ LO
Bits 3 and 4 EQ HI, fixed dB gain adjustment	
OFF OFF	0 dB adjustment, EQ HI [Factory Default]
OFF ON	+2 dB adjustment, EQ HI
ON OFF	+4 dB adjustment, EQ HI
ON ON	+6 dB adjustment, EQ HI
Bits 5 and 6 Ducker dB gain adjustment	
OFF OFF	Full Duplex (no attenuation)
OFF ON	-6 dB attenuation [Factory Default]
ON OFF	-12 dB attenuation
ON ON	Half Duplex
Bits 7 and 8 AGC and Noise Gate settings	
OFF OFF	Phone AGC = OFF, Noise Gate = OFF
OFF ON	Phone AGC = ½ Full, Noise Gate = OFF
ON OFF	Phone AGC = Full Noise Gate = OFF [Factory Default]
ON ON	Phone AGC = Full Noise Gate = Normal

OPTIONS	Function
Bits 1 and 2	DDEQ configuration
OFF OFF	DDEQ feature is turned OFF
OFF ON	Fixed EQ mode (Use SETTING Bits #1, 2, 3, 4 to set the levels)
ON OFF	Adaptive EQ mode [Factory Default]
ON ON	Adapt + Fixed EQ (Use SETTING Bits #1, 2, 3, 4 to set the Fixed levels)
Bits 3 and 4	Auto-Answer configuration
OFF OFF	Auto-Answer = OFF [Factory Default]
OFF ON	Auto-Answer = ON, Auto-answer after first ring
ON OFF	Auto-Answer = ON Auto-answer after third ring
ON ON	Auto-Answer = ON Auto-answer after eighth ring
Bit 5	Send additional gain to caller
OFF	No additional gain is applied [Factory Default]
ON	+3 dB additional gain is applied to the audio sent to the caller
Bit 6	Hx2 internal mix-minus enable
OFF	Independent: Internal mix-minus is disabled. [Factory Default]
ON	Coupled: Internal mix-minus is enabled.
Bit 7	Feedback Reduction enable
OFF	Acoustic Echo Canceler is disabled [Factory Default]
ON	Acoustic Echo Canceler is enabled (use in "open speaker" situation)
Bit 8	Reserved
OFF	Reserved for future use [Factory Default]
ON	Not Recommended

A3 Quick Reference Guide: Internal Switches & Remote Connector Pin Usage

Internal DIP Switch bank: Line Voltages and Impedance

Bit 1	Bit 2	Bit 3	Bit 4	Telephone Network
OFF	OFF	OFF	OFF	USA, Canada
OFF	OFF	OFF	ON	Japan, low voltage networks
OFF	OFF	ON	OFF	FCC compliant countries
OFF	OFF	ON	ON	CRT21, Europe (real line impedance)
OFF	ON	OFF	OFF	Custom country configuration
OFF	ON	OFF	ON	Custom country configuration
OFF	ON	ON	OFF	Custom country configuration
OFF	ON	ON	ON	Europe (complex line impedance)
ON	OFF	OFF	OFF	Custom country configuration
ON	OFF	OFF	ON	Custom country configuration
ON	OFF	ON	OFF	Custom country configuration
ON	OFF	ON	ON	Reserved for future use
ON	ON	OFF	OFF	Reserved
ON	ON	OFF	ON	Reserved
ON	ON	ON	OFF	Reserved
ON	ON	ON	ON	Reserved

Internal DIP Switch bank: Call Progress Tone Disconnect options

Bit 5	Bit 6	Bit 7	Bit 8	CPTD Signal characteristics
OFF	OFF	OFF	OFF	US dial tone ("precise" dial tone)
OFF	OFF	OFF	ON	US re-order signal ("fast busy" tone)
OFF	OFF	ON	OFF	WORLD, single freq. Dial tone
OFF	OFF	ON	ON	WORLD, Re-order, ON=155 - 550, OFF=155 - 550 msec
OFF	ON	OFF	OFF	WORLD, Re-order, ON=250 - 1200, OFF=250 - 1200 msec
OFF	ON	OFF	ON	WORLD, multi-tone dial tone
OFF	ON	ON	OFF	WORLD, multi-tone dial tone
OFF	ON	ON	ON	WORLD, pulse dial tone, ON=150 - 350, OFF=450 - 1100 msec
ON	OFF	OFF	OFF	WORLD, pulse dial tone, ON=100 - 250, OFF=200 - 400 msec
ON	OFF	OFF	ON	Reserved for future use
ON	OFF	ON	OFF	Reserved
ON	OFF	ON	ON	Reserved
ON	ON	OFF	OFF	Reserved
ON	ON	OFF	ON	Reserved
ON	ON	ON	OFF	Reserved
ON	ON	ON	ON	Call Progress Tone Detection (CPTD) feature is disabled

REMOTE connector pin usage

Pin	Direction	Unit	Function
1	GPIO Ground		
2	GPIO Input	Hybrid #1	Hybrid ON
3	GPIO Input	Hybrid #1	Hybrid OFF
4	GPIO Input	Hybrid #2	Hybrid ON
5	GPIO Input	Hybrid #2	Hybrid OFF
6	GPIO Output	Hybrid #1	Line Ringing Indicator
7	GPIO Output	Hybrid #1	Hybrid in use Indicator
8	GPIO Output	Hybrid #2	Line Ringing Indicator
9	GPIO Output	Hybrid #2	Hybrid in use Indicator

Telos[®]

THE TELOS ALLIANCE[®]

1241 Superior Ave. • Cleveland, Ohio, 44114, USA • +1.216.241.7225 • TelosAlliance.com
© 2018 TLS Corp., All Rights Reserved. C18/17047 PN: 1490-00062-002---USER MANUAL: HX1/HX2